

olivetti



ECR 350 euro electronic cash register

INSTRUCTIONS

Ⓜ GB

Disclaimer

The information in this manual is correct at the time of going to press and subject to change without notification. Neither the manufacturer nor any of its official distributors, resellers and / or agents accepts any responsibility for consequential losses and damages as a result of any omissions and / or errors that may be contained within this operating manual

Safety Precautions

CAUTION :-

- *The socket outlet should be near the cash register and easily accessible*

NEVER: -

- *Allow liquid to enter the cash register. If this should happen, unplug the register immediately*
- *Attempt to disassemble or modify the register in any way. The components inside the register carry a voltage, which may emit an electric shock.*
- *Use cleaning fluids; always use a dry cloth to clean the register*
- *Insert any object into the moving components of the register.*

Contents - Programming

Chapter 1 – Getting Started Explanation

SAFTY PRECAUTIONS	3
WELCOME	12
MODE SWITCH	13
DRAWER	13
DISPLAY	14
PAPER ROLL	14
SAMPLE RECEIPT	15

Chapter 2 – Functions Explained

PICTURE OF KEYBOARD.....	18
PRINTING FUNCTIONS.....	19
GENERAL FUNCTIONS	19
PRODUCT KEYS	19
DISCOUNT AND SURCHARGES.....	19
PAYMENT KEYS.....	20
CORRECTIONS AND REFUNDS	20
MONIES MANAGEMENT.....	21
CURRENCY EXCHANGE	21

Chapter 3 – Quick Set-up

RESETTING ALL PROGRAM BACK TO FACTORY DEFAULTS	24
SETTING THE DATE AND TIME.....	24
SETTING THE REGISTER PRINT FORMAT	24
RESETTING ALL PROGRAM BACK TO FACTORY DEFAULTS	25
RESETTING THE GRAND TOTALS	26
RESETTING THE REPORTS.....	25
RESETTING THE CONSECUTIVE RECEIPT	26
RESETTING THE ELECTRONIC JOURNAL	26
RESETTING ALL TOTALS.....	25

Chapter 4 – Programming

SETTING THE DATE AND TIME.....	32
SETTING THE REGISTER PRINT FORMAT	32

Contents - Programming

Product Programming

- SETTING A PRE-SET PRICE FOR A DEPARTMENT.....33
- SETTING A PRE-SET PRICE FOR A PLU.....33
- SETTING A NAME FOR A DEPARTMENT.....34
- SETTING A NAME FOR A PLU.....34
- SETTING DEPARTMENT ALL FEATURES.....35
- SETTING PLU ALL FEATURES.....36
- SETTING GROUP NAMES37
- SETTING LOGO DETAILS37
- SETTING CLERK DETAILS.....37

Function Feature Programming

- SETTING % 1 & % 2 SPECIAL FEATURES38
- FORCING AN AMOUNT TENDERED39
- CREDIT CARD39
- VAT RATES.....39
- COPY RECEIPT40
- #/NO SALE40
- EURO / CURRENCY41

System Feature Programming

- DECIMAL PLACES / DATE FORMAT AND VAT ADD OR EXTRACT42
- MACHINE NUMBER42
- RECEIPT PRINT FORMATTING.....43
- REPORT FORMATTING.....44
- ELECTRONIC JOURNAL / REPORT OPTIONS.....44
- GENERAL SETTINGS45
- SELF TEST/PRINTER FEED LINES45
- EXCHANGE RATE.....46

Printing Programmed Information

- PRINTING ALL PRE-PROGRAMMED PLU DATA.....47
- PRINTING ALL PRE-PROGRAMMED CLERK DATA.....47
- PRINTING ALL PRE-PROGRAMMED SYSTEM FLAG DATA48
- PRINTING ALL PRE-PROGRAMMED DEPARTMENT DATA.....47
- PRINTING ALL PRE-PROGRAMMED GROUP DATA.....48
- PRINTING ALL PRE-PROGRAMMED FOREIGN CURRENCY RATES.....48
- PRINTING ALL PRE-PROGRAMMED TAX RATES.....48
- PRINTING ALL PRE-PROGRAMMED LOGO NAMES48

Contents - Operation

Chapter 5 – Sale Operations

DISPLAYING THE TIME	54
CLERK SIGN ON	54
OPEN PRICED SALE.....	55
PRESET PRICED SALE	55
SEVERAL DEPARTMENTS SALE.....	55
REPEATING THE SAME DEPARTMENT	56
SELLING MULTIPLES OF THE SAME ITEM USING X/TIME	56
NEGATIVE AND SINGLE ITEM SALE DEPARTMENTS	57
OPEN PRICED SALE.....	58
PRESET PRICED SALE	58
SEVERAL PLUS	58
REPEATING THE SAME PLU	59
SELLING MULTIPLES OF THE SAME ITEM USING X/TIME	59
NEGATIVE AND SINGLE ITEM PLUS	60
Payment Operation	
CARD PAYMENT	61
CHEQUE PAYMENT	61
MIXED PAYMENT MEDIA	61
PAY IN MONIES TO THE CASH DRAWER	62
PAY OUT MONIES FROM THE CASH DRAWER	62
OPENING THE CASH DRAWER.....	62
ISSUE A COPY RECEIPT	62
BACKTRACK COPY RECEIPT	62
PAYMENT IN EUROS	63
PAYMENT IN DOLLARS	63
Premium and Discount Operations	
ITEM MONETARY DISCOUNT	64
SALE MONETARY DISCOUNT	64
ITEM % DISCOUNT	65
SALE % DISCOUNT	65
ITEM MONETARY SURCHARGE	66
ITEM % SURCHARGE	67

Contents - Operation

Void and Refund Operations

- VOID LAST ITEM68
- REFUND ITEM – WITHIN A SALE68
- REFUND – OUTSIDE OF A SALE.....69
- CANCEL TRANSACTION.....69
- VOID A WHOLE TRANSACTION.....69
- STARTING TRAINING MODE70
- REGISTER SALES IN TRAINING MODE.....70
- ENDING TRAINING MODE.....70
- TRAINING MODE FINANCIAL REPORT70

Chapter 6 – Reporting

- DISPLAYING AND DECLARING CASH IN DRAWER.....72
- PRINTING A SHORT READ OF THE DRAWER TOTALS72
- READ REPORTS73
- RESET REPORTS.....75

Sample Reports

- VOID REPORT76
- CLERK REPORT.....77
- FULL REPORT.....78
- DECLARED REPORT79
- DEPARTMENT REPORT80
- GROUP REPORT80
- SHORT DEPARTMENT / GROUP REPORT81
- PLU REPORT.....81
- DAILY REPORT82
- HOURLY REPORT82

Chapter 7 – Trouble Shooting

Getting Started



Chapter 1

Getting Started Explanation

Getting Started

General Guide

Welcome

This cash register has been designed to provide you with comprehensive management reports, through simple register operations. The requirements of your business will be met by the register's features, which are outlined in this manual.

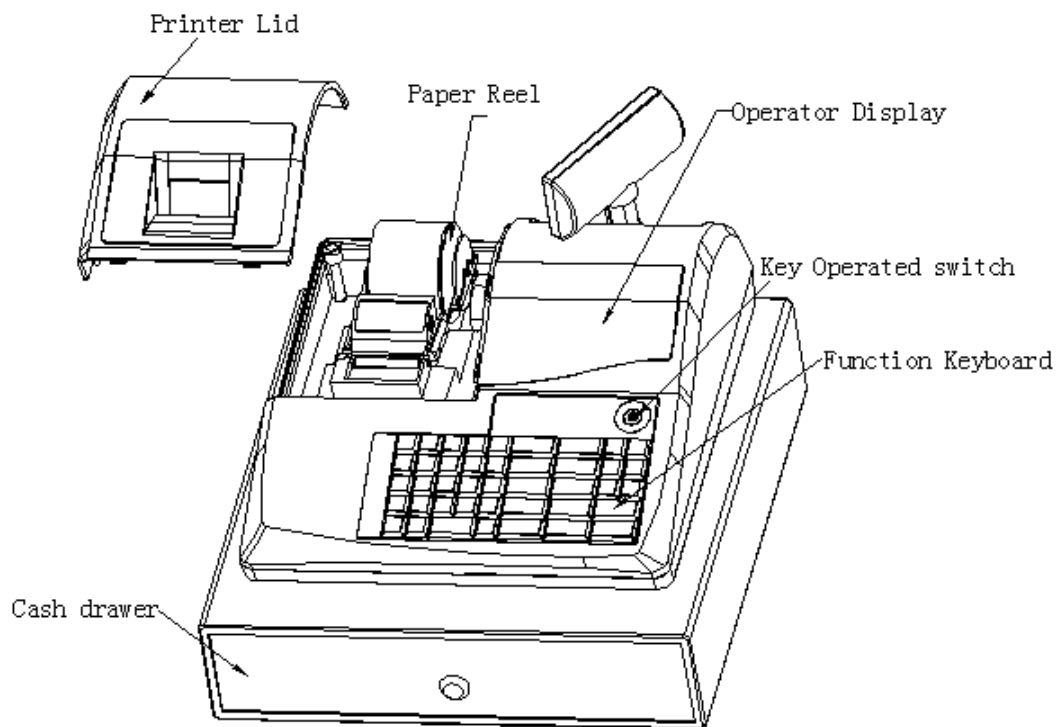

Getting Started

Mode Switch

This has five mode positions for providing secure access to the registers options.

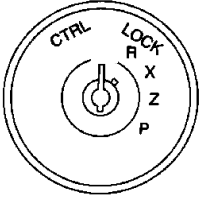

- L** The register is locked in this position and no sales can be entered.
Any key can be turned to this position, and removed.
- R** This will display the time when initially turned to this position.
Press CLEAR to remove the time display or simply begin the operation.
Sales transactions can be registered in this mode.
Any key can be turned to this position, and removed.
- X** **XREPORT** is shown on the display. Reports can be printed without deleting sales totals.
The total monies in drawer is also displayed when the key is turned to X mode
Any key can be turned to this position.
- Z** **ZREPORT** is shown on the display. Reports can be printed and this will delete the sales totals. The total monies in drawer is also displayed when the key is turned to Z mode
The **OW** key is required for this position
- P** **PROGRAM** is shown on the display when this mode is selected.
This mode is used to program the system flags, departments, items, prices, etc.
The **OW** key is required for this position
- VOID** This will display the time when you initially turn to this position.
Press CLEAR to remove the time display and begin operation
In this mode, all the operations are the same as R mode, but the calculation is negative
The **OW** key is required for this position

Note Turning the mode key mid operation will result in an error tone.
Return to the original position press CLEAR then finalise the current operation before turning the mode lock key.

Drawer

The cash drawer has four note and eight coin compartments with a removable insert. The drawer will open when a sale is finalised or when a report is printed.

Please Note:- That there is a manual release level underneath the drawer in case of power failure.

Getting Started

Display

As transactions are made, the display shows the current sale. The display supports varying symbols to indicate to the user what has been currently entered

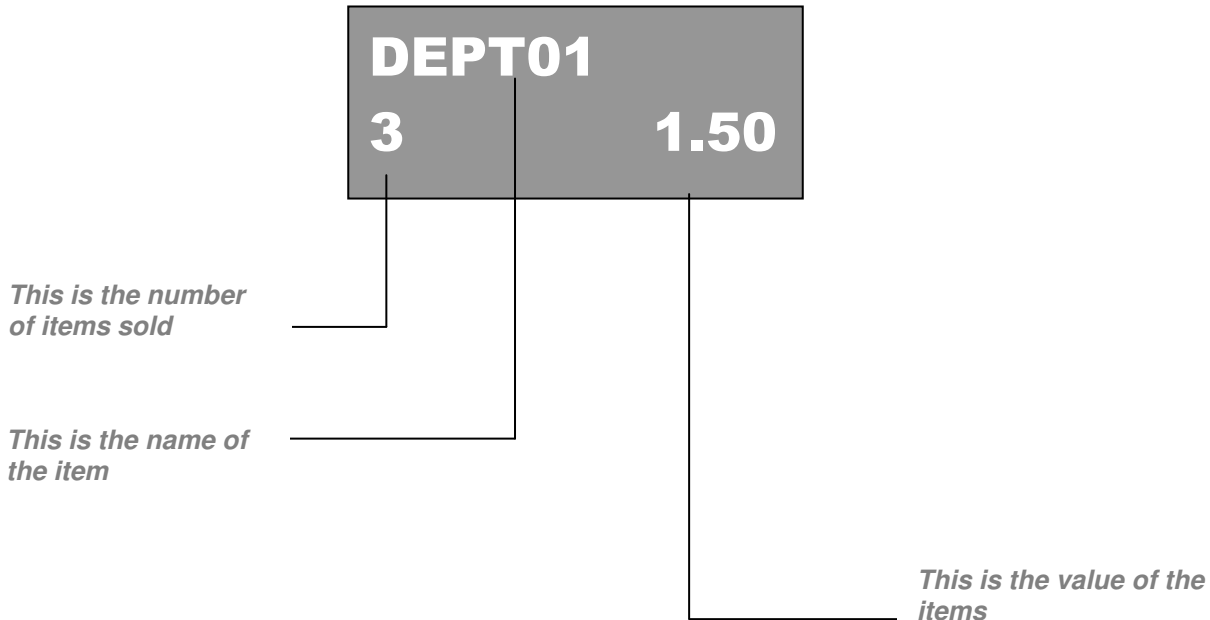

Paper Roll

The register operates using 57mm by 70mm thermal paper roll. This is given to the customer as a receipt or wound round the take up spool for recording of the daily transaction journal. It is possible to stop any printing as shown in the program options. The register also has the option to store the journal electronically. This will store each sale, until such time as the journal memory is full, at this stage the system will either clear the report automatically and start recording again, or the register will prompt the user to print and reset the report. This can be programmed using system option 7.

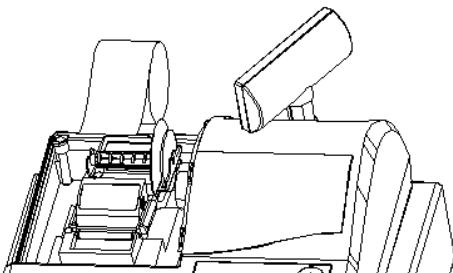

To Install the Paper :-

Remove the roll cover, open the paper arm, drop the roll in as shown and then close the paper arm.

It is then possible to feed the paper onto the take up spool if required

Caution: - Do not tamper with the printer mechanism or use the machine with no paper fitted as this may cause irreparable damage.

Getting Started

Receipt Explanation

Sample Receipt

Example printout

* YOUR RECEIPT *	
* THANK YOU *	

11/05/03 14-10 000	
2X @1.00	
DEPT01 T1 2.00	
SUBTOT 2.35	

SUB-T 2.00	
TAX1 17.5% 0.35	
VAT TOTAL 0.35	

TOTAL 2.35	

CASH 5.00	
CHANGE -2.65	

#ITEMS 2	
CLERK 1 0000	

THANK YOU	
PLEASE CALL	
AGAIN	

Programmable Company header message

Date, time and register number

Quantity of 2 at 1.00 value

Programmable Department name, tax indicator and price

Value of the sale including the Add on Tax

Value of the sale excluding the Add on Tax

Programmable tax rate, name and the value of Tax

Total of all Tax payable by all rates within this sale

Total amount due by the customer

Total value of monies paid by the customer

Value of change due to the customer

Number of items purchased within this sale

Programmable Company footer message

* The information printed on the receipt is decided in programming. The example above shows a fully detailed receipt, with optional tax add on.

Chapter 2

Functions Explained

Function Keyboard

Function Explanation

Keyboard

The cash register keyboard controls all operations of the machine, from basic registration to refunds and reports. The action of each key is dependant on the mode switch position or the sequence of key presses. Specific programming functions can be carried out on the cash register, such as presetting the % key with a fixed discount amount i.e 10%. A detailed explanation of these functions is shown in the following sections.

PAPER FEED	RECPT ON/OFF	CLEAR	.	X/TIME	CLERK#	PLU # / AMT	V CURR #1	Y CURR #2
VAT/SHIFT	COPY RECPT	7	8	9	#4	#8	MISC TEND	NO SALE / #
R . A	P . O	4	5	6	#3	#7	CHEQ	CAPS CARD
%1 (%-)	%2 (-)	1	2	3	#2	#6	ENTER SUBTOTAL	
VOID LAST	REFND/ CANCL	0		00	#1	#5	SPACE CASH	

Functions Explained

Printing functions

**PAPER
FEED**

This will feed the paper roll

**RECPT
ON/OFF**

This is used to turn the receipt on or off.

**COPY
RECPT**

This is used to issue a customer copy of the receipt. It is possible to back track through the last three receipts, by entering the number 1 2 or 3 and pressing this key.

General Functions

0

to

9

These are numeric keys used to make entries.

.

It should be noted the decimal position is used only for entering decimal quantities during multiplication

CLEAR

This key is used to clear a numeric amount which has not been registered through a department or PLU, or to stop the error tone of the register

**X /
TIME**

This key is used during transactions to enter multiple quantities of the same item. Outside of a sale this key will display the current time

SUBTOTAL

This function is used to display the current sale total during a transaction.

Product Keys

**PLU /
AMT**

The system allows 1200 Price Look Up codes to be programmed to the cash register memory for open or preset price sales. Entering the code number of the product and pressing this key will register the item sale.

#1

The eight department keys are used to register sale items either as open or pre-set price items

Discount and Surcharges

**% 1
(%-)**

This key can be programmed to carry out any monetary/percentage discount or surcharge operation within a sale. A rate can be pre-programmed to the key for fixed amounts. The key as default is programmed to act as an open percentage minus amount

**% 2
(-)**

This key can be programmed to carry out any monetary/percentage discount or surcharge operation within a sale. A rate can be pre-programmed to the key for fixed amounts. The key as default is programmed to act as an open minus amount

Functions Explained

Payment Keys

CASH

This key is used to accept payment of a transaction as cash. If an amount is entered prior to pressing this key it is treated as an amount tendered and change will be calculated. When the sale is finalised the cash drawer opens and the totals are reported to Cash In Drawer. The system will accept partial payment in conjunction with any other payment keys.

CARD

This key is used to accept payment of a transaction for up to 9 Credit Card types. When the sale is finalised the cash drawer opens and totals are reported to Card In Drawer. The system will accept partial payment in conjunction with other payment keys.

CHEQ

This key is used to accept payment of a transaction by cheque. When the sale is finalised the cash drawer opens and the totals are reported to Cheque In Drawer. The system will accept partial payment in conjunction with any other payment keys.

**MISC
TEND**

This key is used to accept payment of a transaction, by miscellaneous tender. When the sale is finalised the cash drawer opens and totals are reported to misc in drawer. The system will accept partial payment in conjunction with any of the payment keys.

Corrections and Refunds

**VOID
LAST**

This key can be used at any time within a transaction. When pressed after a department or PLU it will remove that item from the sale total.

**REFND
/CANCL**

This is a dual function key acting as a refund allowing any item to be refunded even if the item has not been sold within the current transaction. The key will also act as a complete transaction cancel if pressed after the subtotal key.

Functions Explained

Monies Management

P.O.

This key is used to register monies taken out of the drawer. The value is entered followed by the P.O key and then finalised using one of the payment keys. The value paid out will then be deducted from the report totals.

R.A.

This key is used to register monies paid into the drawer. The value is entered followed by the R.A key and then finalized using one of the payment keys. The value received on account will be added to the report totals.

/ NO
SALE

This is a dual function key. Used outside of a sale the No Sale key will open the cash drawer. Alternatively a reference number can be entered on the numeric keypad followed by the # key. The number entered will be printed on the paper roll.

Currency Exchange

CURR
#1

These functions allow payment in up to two foreign currencies. The Euro currency is the first rate of exchange. The system can accept partial payment of foreign and home currency, with the ability to select the receipt print format totals printing in both Euro and foreign currency amounts.

CURR
2

To make a sale in Euros the key is pressed immediately after the subtotal key followed by the payment function. If a sale is to be made in a different currency the subtotal key is pressed followed Curr #2 key. The display will show the value of the sale in the currency chosen.

Chapter 3

Quick Set-up

Quick Set-up – Basic Programming

Quick Set-up

The following sequences are the only ones required before beginning basic register operations. Once you have unboxed the cash register and ensured that all the components are enclosed. You MUST reset the machine using the “Resetting all program back to factory defaults” operation shown below. This procedure can be carried out at any time, however any programming or sales information previously entered will be erased.

Resetting all Program Back to Factory Defaults

This will restore the program back to factory settings removing any previously carried out programming and sales totals stored in the register

Note :- ALL PROGRAMMING WILL BE LOST AND THE MACHINE WILL BE CLEARED OF ALL TOTALS

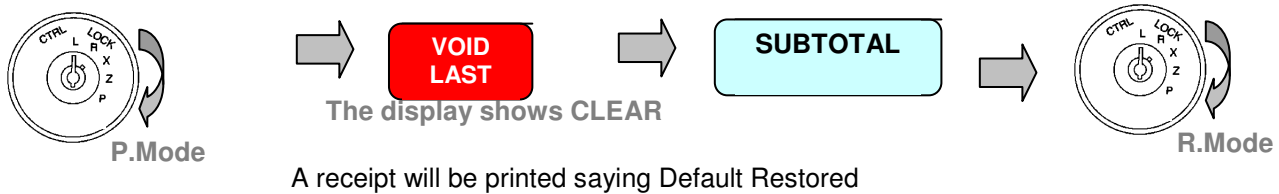

Setting the date and time

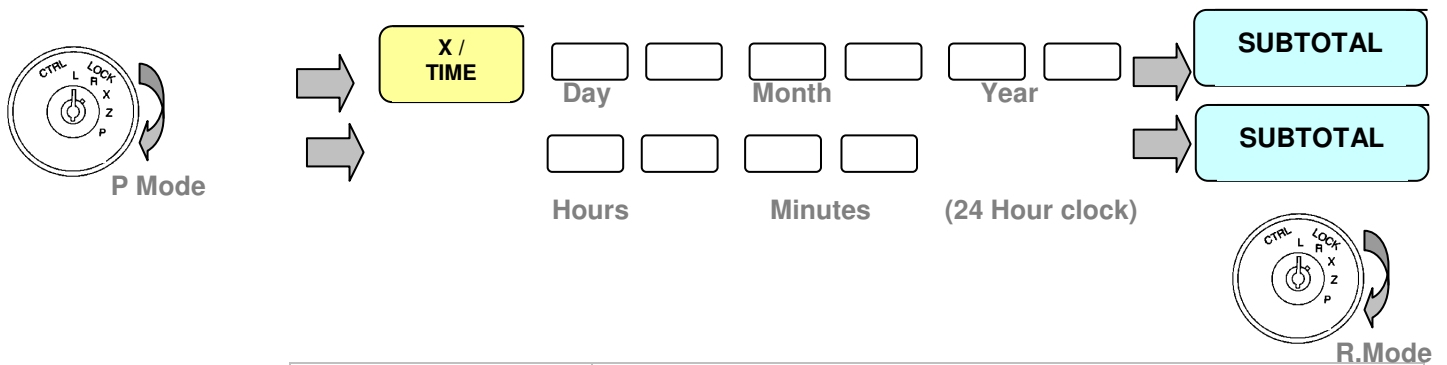

Example | 22, January 2003 at 1.00pm

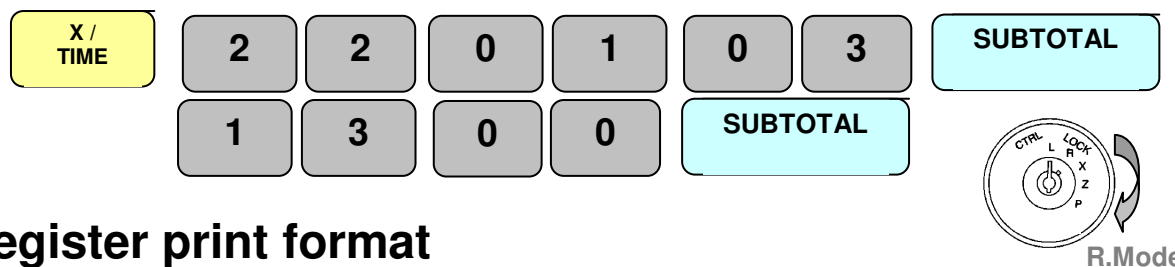

Setting the register print format

The register has a single roll printer. This roll can be used to issue receipts to customers or to record the sales on the journal. The register has the ability to store the journal electronically turned on within program option 7.

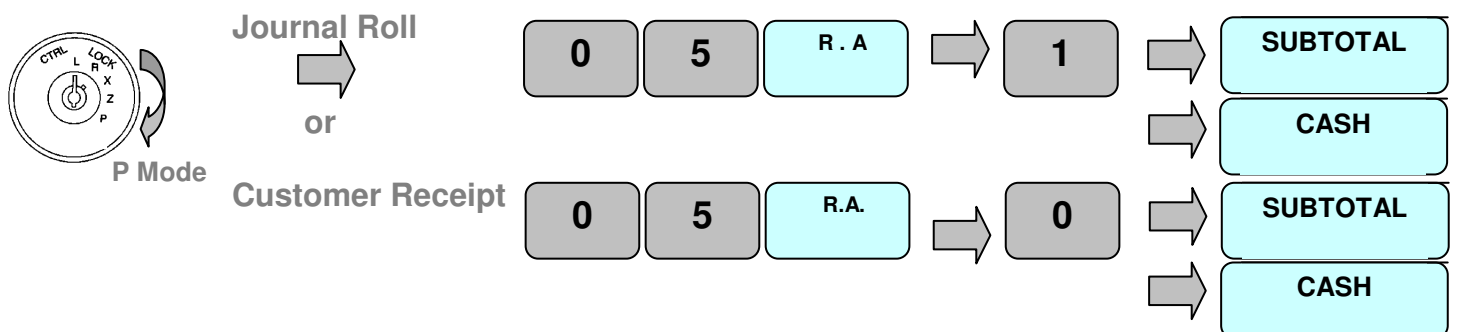

Management Reset of Totals

Memory Operations

It is possible to reset all totals back to factory defaults or to remove various combinations of sales totals. This allows you to familiarise yourself with the machine, and remove all totals before beginning programming.

Resetting all Program Back to Factory Defaults

This will restore the program back to factory settings removing any programming previously carried out and sales totals stored in the register

Note :- ALL PROGRAMMING WILL BE LOST AND THE MACHINE WILL BE CLEARED OF ALL TOTALS

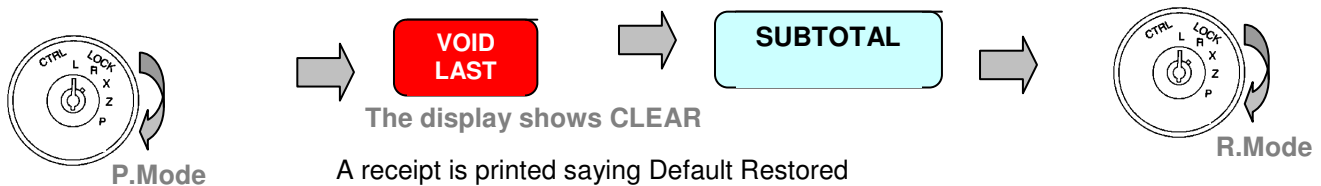

Resetting the Reports

This will reset the X-read and Z-reset report totals

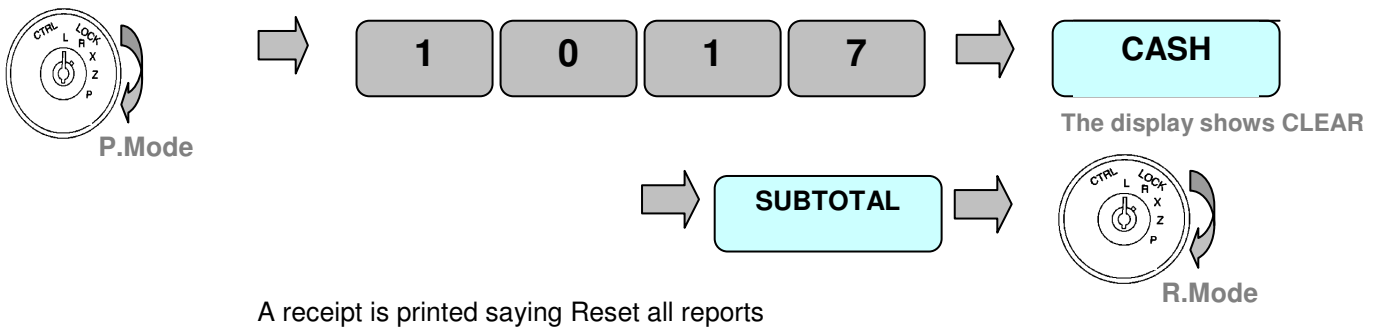

Resetting all totals

This will reset the related sales totals and counters, this will not reset the grand totals and receipt numbers

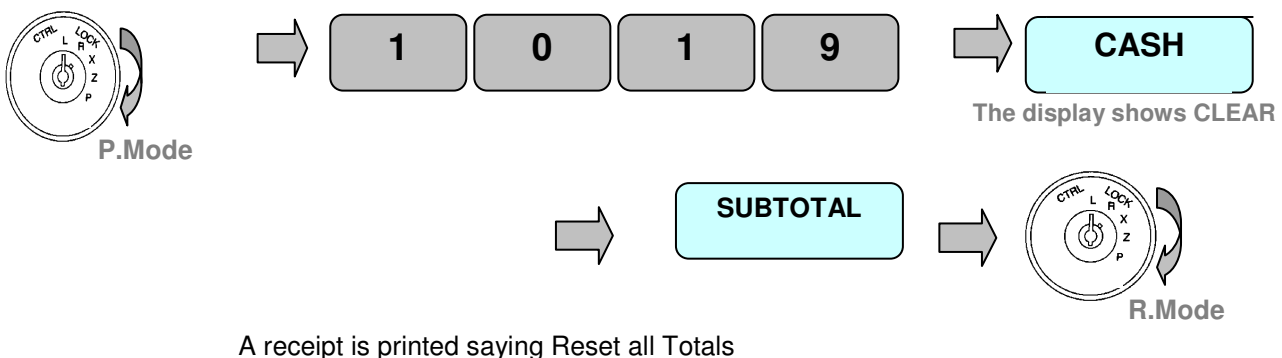

Management Reset of Totals

Resetting the consecutive receipt

This will reset the customer receipt consecutive number and also the report consecutive number

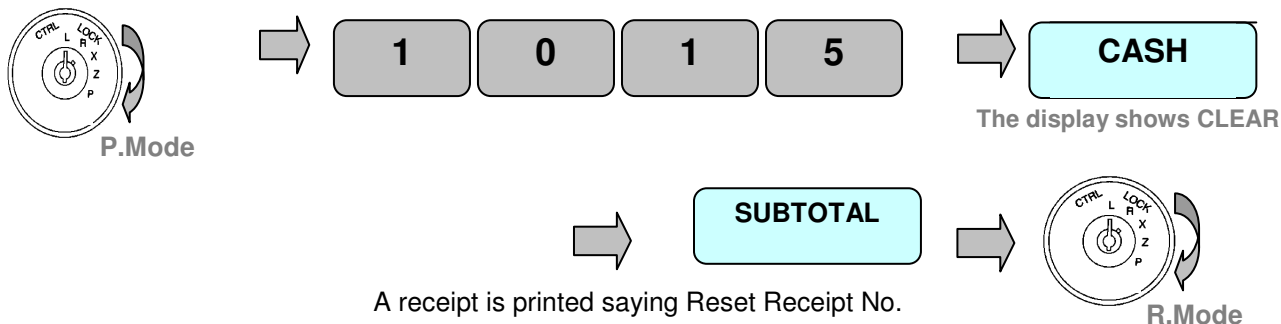

Resetting the Electronic Journal

This will reset the electronic journal roll totals, provided this is allowed using the system settings within flag 7

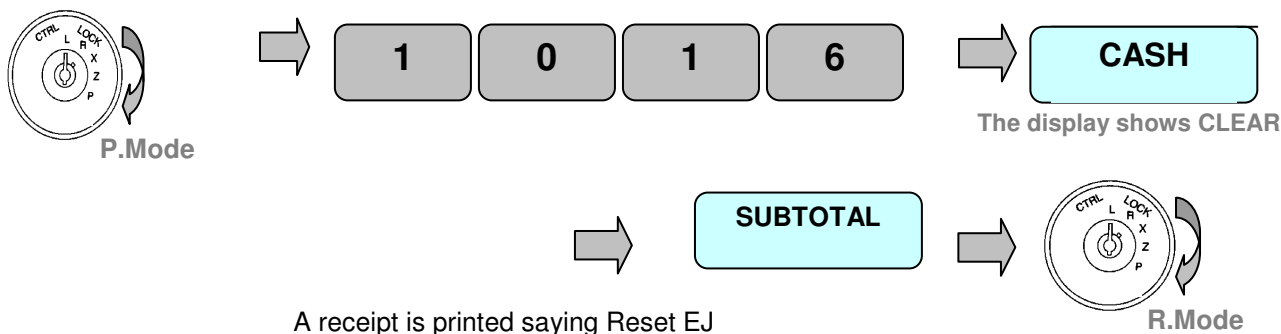

Resetting the Grand Totals

This will reset the running grand total which appears on the reset report

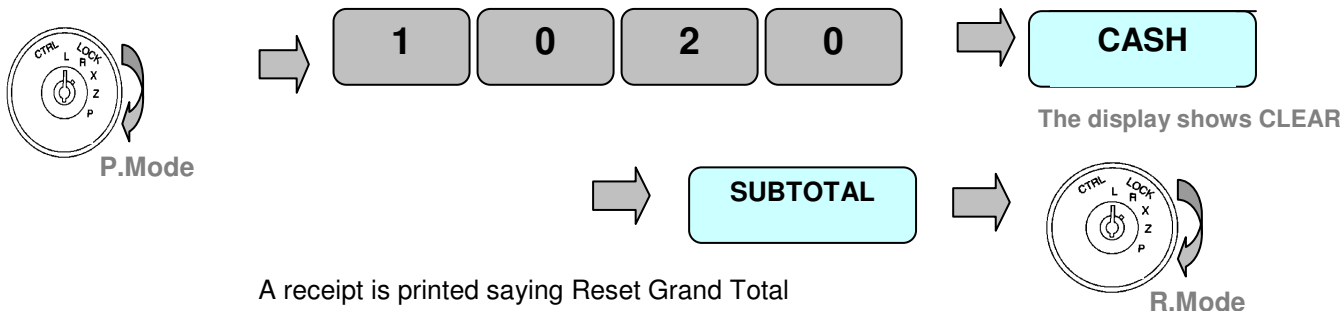

Programming



Chapter 4

Programming

Program Settings

Basic Settings

The following tasks should be carried out when the machine is removed from the box

Setting the date and time

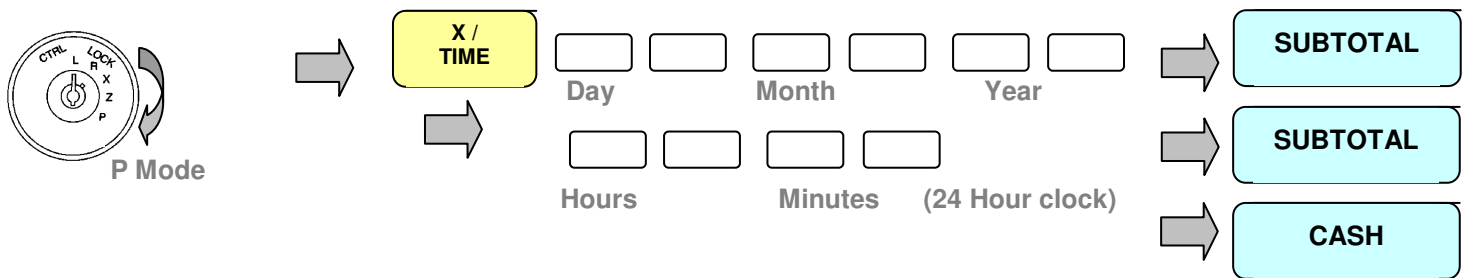

Example

22, January 2003 at 1.00pm

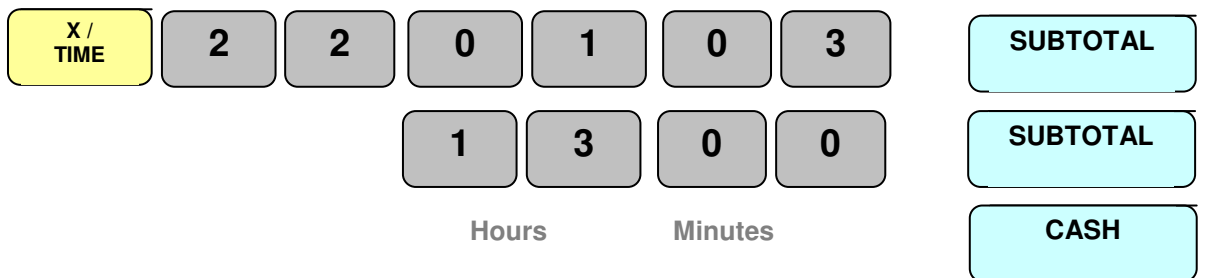

Setting the register print format

The register has a single roll printer. This roll can be used to issue receipts to customers or to record the sales on the journal. The register has the ability to store the journal electronically turned on within program option 7.

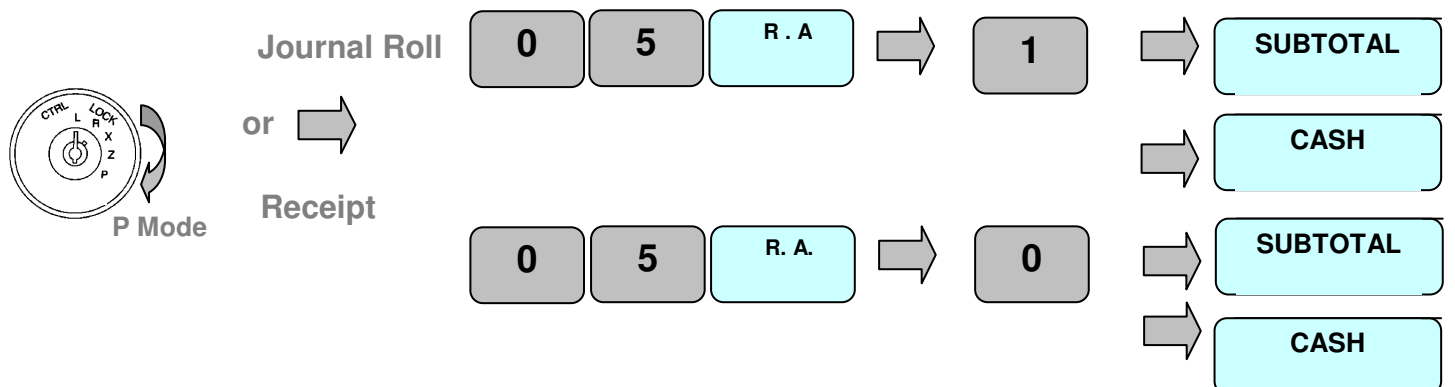

Program Settings

Programming Prices Only

The departments on the keyboard as standard allow manual entry of prices. However, it is possible to program a preset price to a department. There are other features relating to departments such as tax status as shown on the following pages.

Setting a pre-set price for a Department

The eight department buttons on the keyboard can be programmed with a preset price

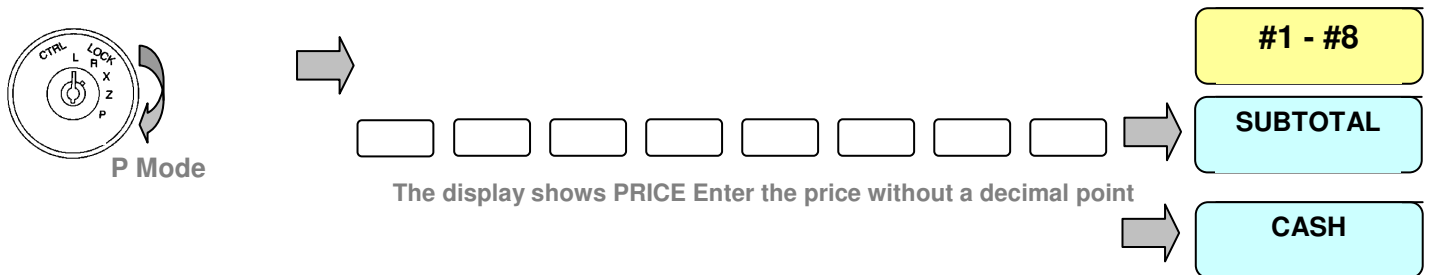

Example To program department 1 for a price of £2.10

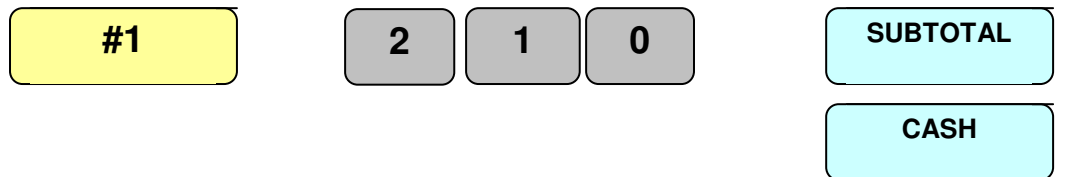

Setting a pre-set price for a PLU

The register allows up to 1200 Price Look Up codes to be programmed in cash register memory. PLUs are used to register items by entering the PLU code and pressing the PLU button. There are other features relating to PLUs on the following pages.

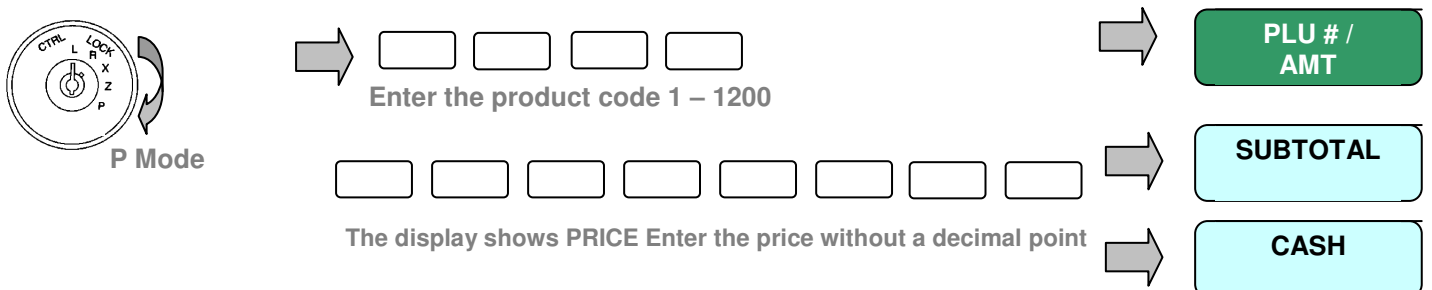

Example To program product code 12 for a price of 20p



Program Settings

Programming Names Only

The departments on the keyboard as standard are operational, allowing the manual entry of prices. However to provide a more meaningful receipt for the customer, it is possible to program a name to a product. This procedure is shown below.

Setting a name for a Department

The eight department buttons on the keyboard and up to 99 memory departments can be programmed with a preset name that is printed on reports etc.

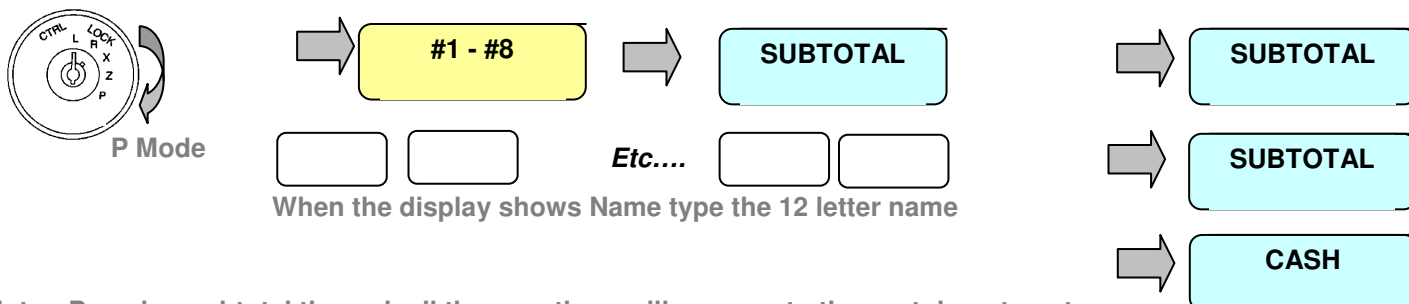

Note:- Pressing subtotal through all the questions will move onto the next department

<i>Example</i>	To program department 1 with a name of CAR
----------------	--

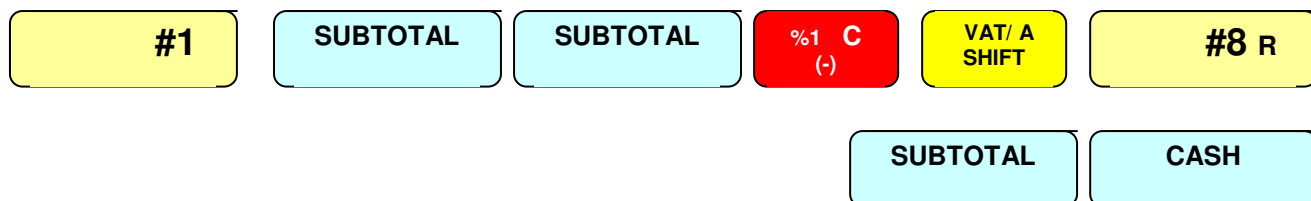

Setting a name for a PLU

The register allows up to 1200 Price Look Up codes to be programmed to the cash register memory. PLUs are used to register items by entering the PLU code and pressing the PLU button. These codes can be given a 12 character name.

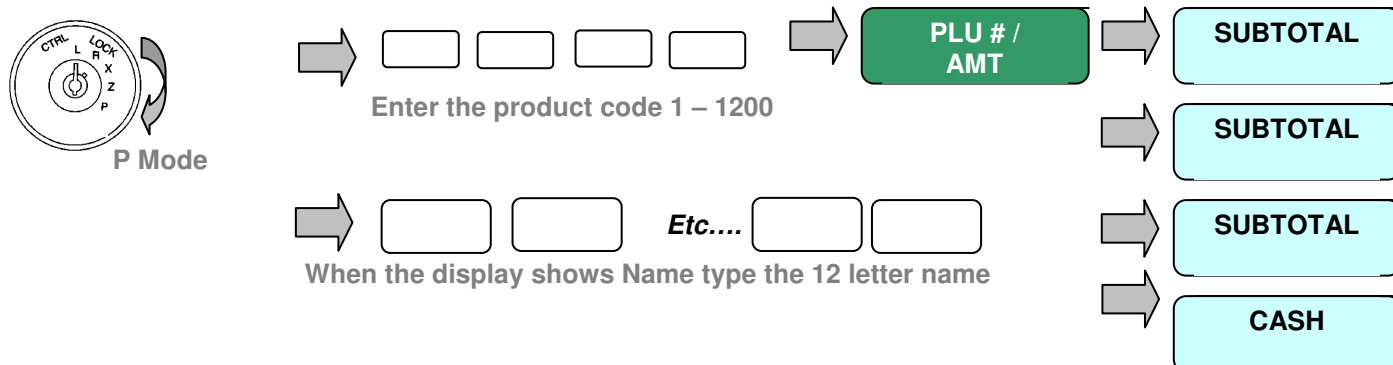

<i>Example</i>	To program product code 12 with a description of CAR
----------------	--

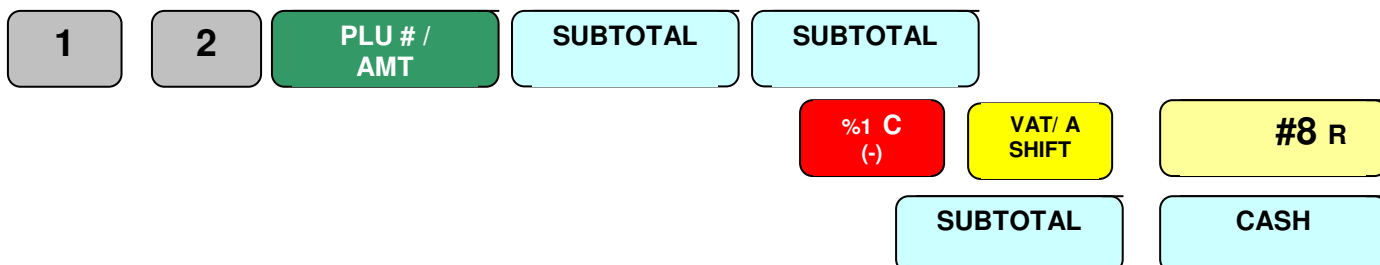

Program Settings

Programming All Department Options

It is possible to program special features to the departments depending on your requirements. For example, an item could be taxable by 17.5% or it may be that the item needs to be negatively priced. The register is programmed by entering a string of numbers, where the number in the string represents turning on a feature. The table below shows the program numbers and what feature each number represents. It is also possible to link departments together into groups so that total sales can be calculated for each group i.e. food and non-food items. There are eight departments on the keyboard for sales and 99 in total, for reporting purposes.

Setting Department Special Features

Note:- Pressing subtotal through all the questions will move onto the next department

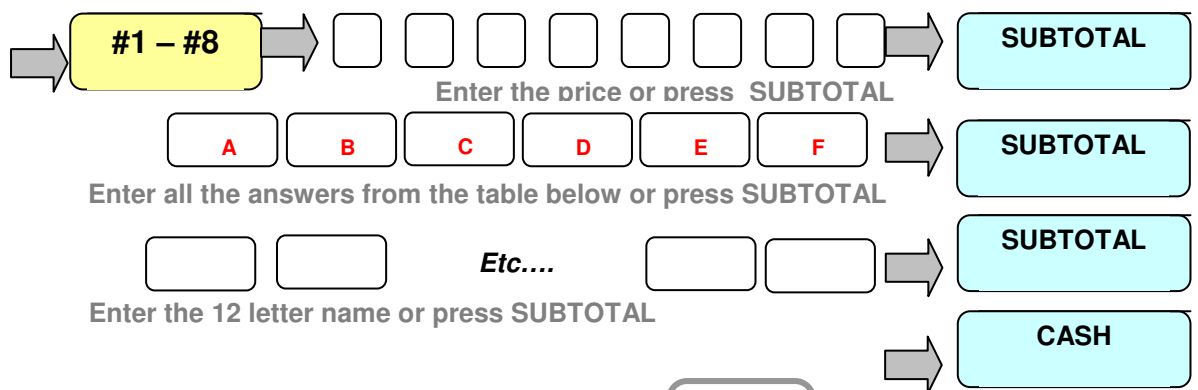
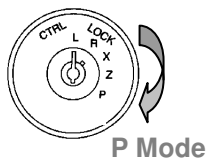

Feature option	Choice	Answer
Normal Price Item Negative Retail Price Item with no price print Do not Print the retail price on the receipt Negative Retail Price Item	0 = Normal Price 2 = Yes 4 = Yes 8 = Yes	<input type="text" value="A"/>
Department to be taxable by the tax rate reference 0 thru to 5	1 to 5 0 = No Tax	<input type="text" value="B"/>
Department allows open price entry	0 = Yes 1 = No	<input type="text" value="C"/>
Which sales reporting group is used for sales totalling of this product. E.g. Group 1 could represent Food, 2 Non Food	0 = No Group 1 - 9 = Groups 1-9	<input type="text" value="D"/>
Is the item to be single item sale i.e. the amount of monies is accepted as cash and the drawer opens immediately It is also possible to sell an item as a zero price	0 = Normal 1 = Single 2 = Zero Price	<input type="text" value="E"/>
To restrict the number of digits allowed for manual price entry i.e. 2 = 99p 3 = £9.99 etc.	1 - 8 = Fixed Limited 7 is standard choice	<input type="text" value="F"/>

Example To program department 1 as taxable by rate 2, sales group 1 with a price of 1.00 with a description of "CAR".

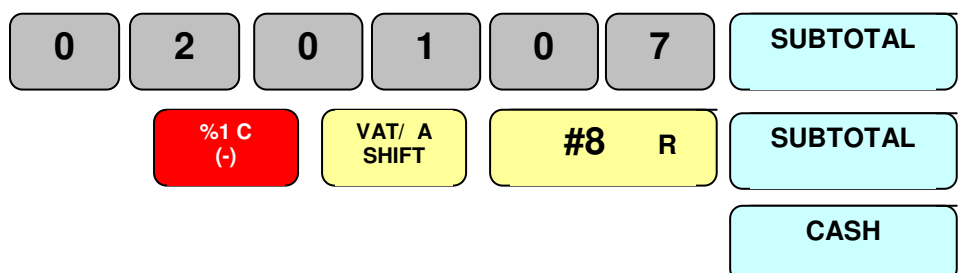

Program Settings

Programming All PLU Options

It is possible to program special features to each PLU depending on your requirements. For example, an item could be taxable by 17.5% or it may be necessary for the item to be negatively priced. The register is programmed by entering a string of numbers where a number in the string represents turning on a feature. The table below shows the string of program numbers and what feature each number represents. It is also possible to link PLUs together into departments which can then be linked to groups so that total sales can be calculated for each group i.e. food and non food items

Setting PLU Special Features

Note:- Pressing subtotal through all the questions will move onto the next PLU number

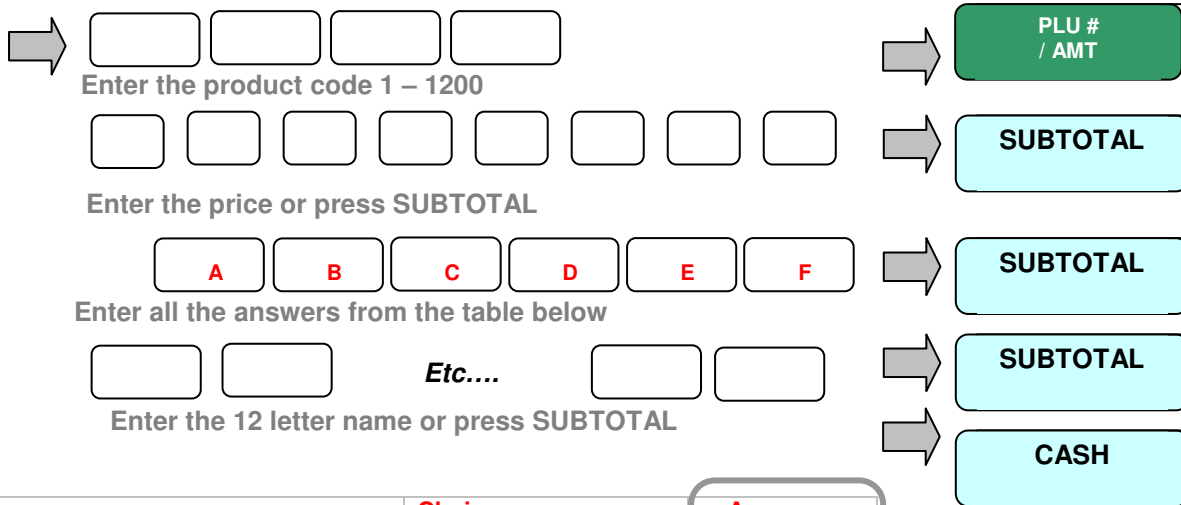
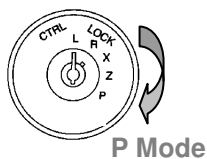

Feature option	Choice	Answer
Open price entry is allowed.	0 = No 1 = Yes	A
Descriptive PLU Enabled, this allows a PLU to add extra information to the receipt i.e. colour or size without totalling	0 = No 1 = Yes	B
Which sales reporting Department is used for sales totalling of this product. E.g., Department 1 on the keyboard could represent Toiletries for both open sales and PLU totalling.	1 = Default Link 1 – 99 Departments 8 key thru to 99 memory	C D
Is the item to be single item sale i.e. the amount of monies is accepted as cash and the drawer opens immediately. It is also possible to sell an item as a zero price	0 = Normal 1 = Single 2 = Zero Price	E
To restrict the number of digits allowed for manual price entry i.e. 2 = 99p 3 = £9.99 etc	1 – 8 = Fixed Limited 7 is standard choice	F

Example To program product code 1 as sales department 08 priced at 50p named Car

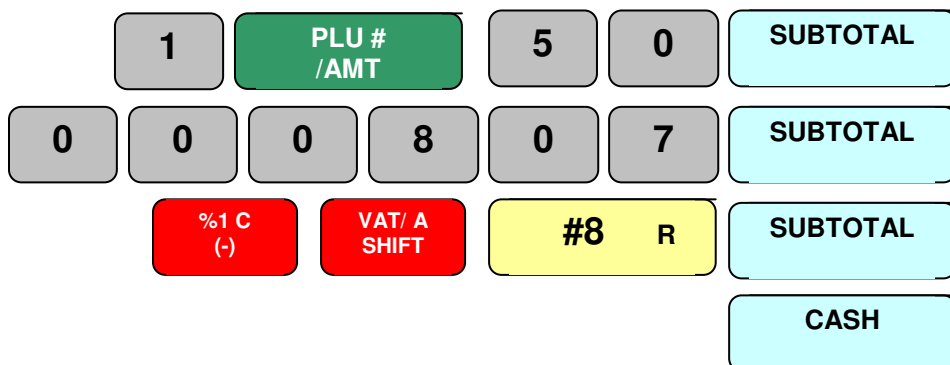

Program Settings

Programming Group Names

Each PLU can be linked to a department and then to a group. For example: A PLU called Bottle of Becks may be linked to a department called Beers which may be linked to a group called Alcohol. This will provide totals per bottle of Becks, total Beer sales and total Alcohol sales.

Setting Group Names

Note:- Pressing subtotal through all the questions will move onto the next Group number

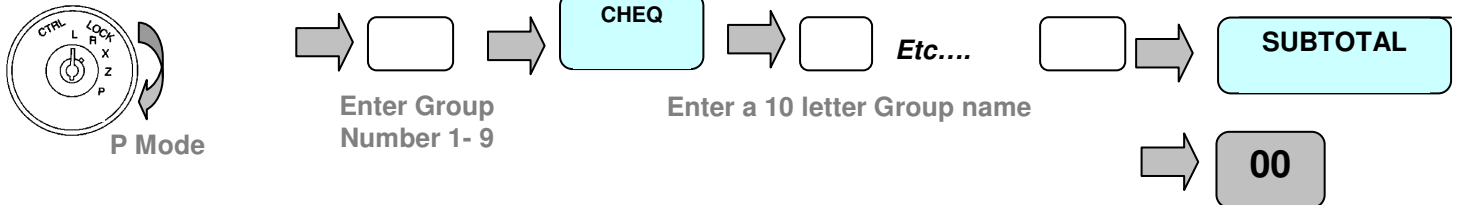

Programming the Company Logo

It is possible to program 11 lines of receipt messaging for company details etc. Lines 1 – 6 are used as the receipt header message and lines 7 –11 as the receipt footer message. It is possible using the system flags to determine how many lines of the receipt header and footer are to be printed.

Setting Logo details

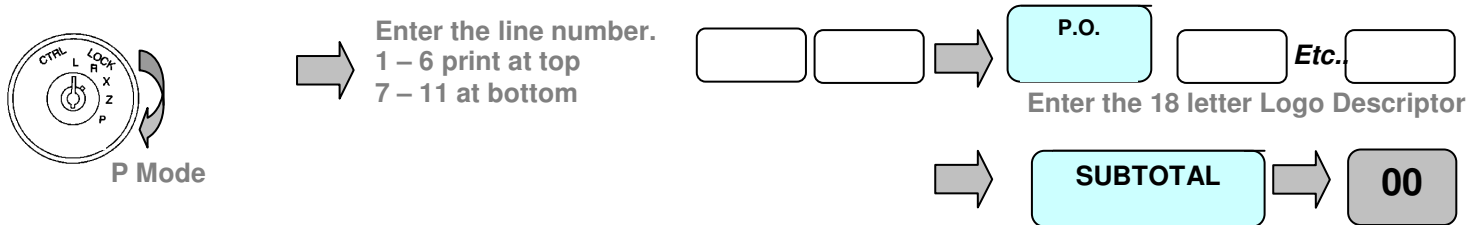

Programming Clerks

It is possible to program clerks, giving each a number, name and password, it is possible using the system flags to enforce a secret password entry per clerk

Setting Clerk details

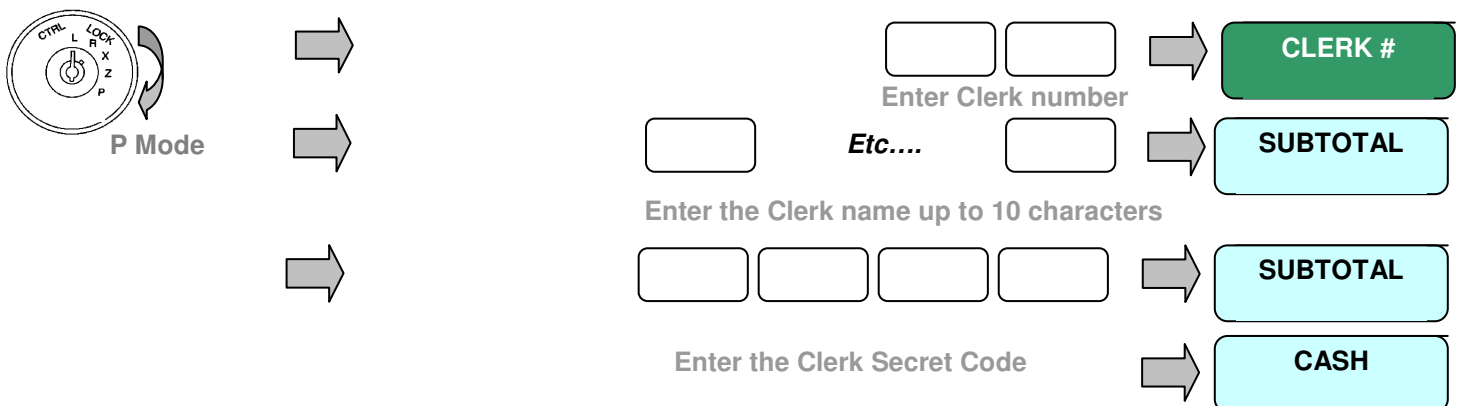

Program Settings

Programming %1 and %2

Setting % 1 & % 2 Special Features

The cash register allows two function keys to be programmed as discount or premium operation keys with either monetary or a percentage value. The function adds to the financial report recording the value of discounts or premiums given. If the % key is pressed immediately after the department or PLU the sales value is reported net of the value to the financial report. Alternatively, if the key is pressed after the subtotal key, only the sales total is reported as a net value and the department or PLU sales are reported gross.

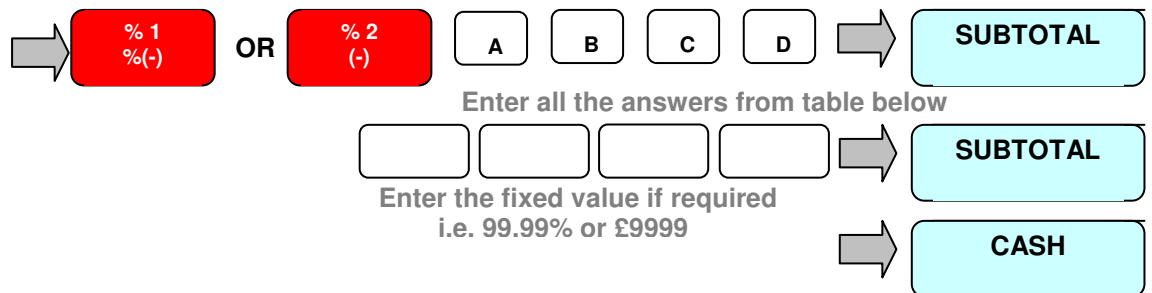
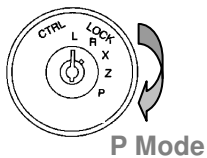

Feature option	Choice	Answer
Allow open discount / amount entry	0=Yes Open 1=No Preset	<input type="text" value="A"/>
Does the discount apply to the item value or to the total sale value	Sale = 1 Item = 0	<input type="text" value="B"/>
Minus or positive value	Minus = 0 Positive = 1	<input type="text" value="C"/>
% or Monetary value	% = 0 Amount = 1	<input type="text" value="D"/>

Example Following is the default settings for the %1 key acting as plus 10% for sale total

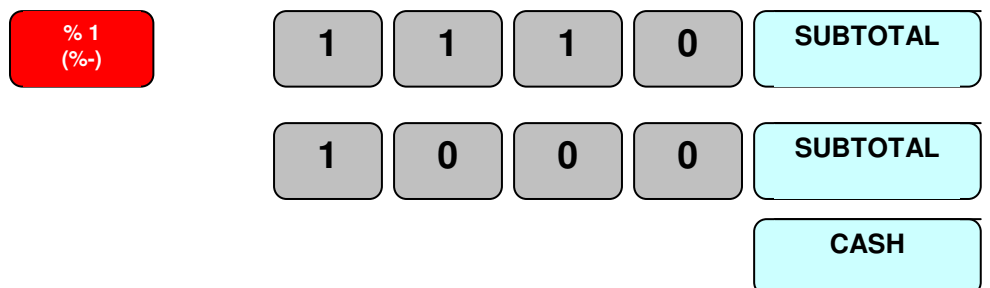

Example Following is the default settings for the %2 key acting as percentage minus 10p per item not allowed on the whole sale total

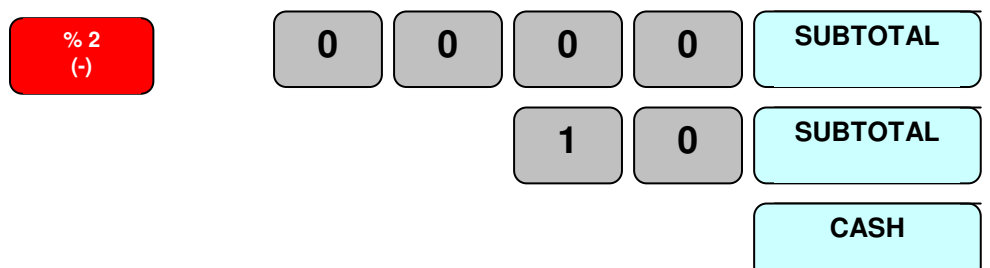

Program Settings

Programming Payment Options

Forcing an amount tendered

It is possible to force the operator to enter the amount given by the customer for every sale, ensuring change is calculated every time.

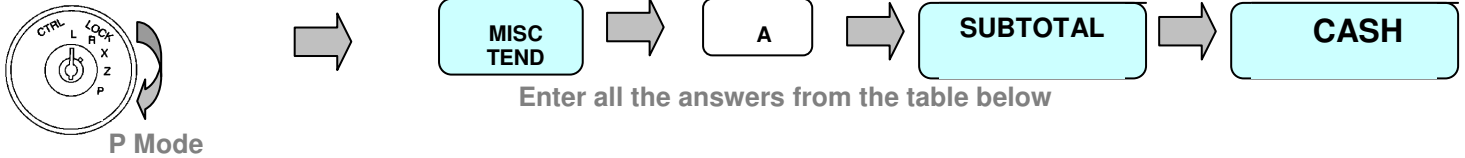

Feature option	Choice	Answer
Compulsory amount tendered.	No = 0 Yes = 1	<input type="text" value="A"/>

Cash and Credit Card Names

There is a single credit card function on the keyboard, this is used to recall up to 9 credit card types, by entering the number and pressing the key. Each of these credit card payments can be pre-programmed with a name.

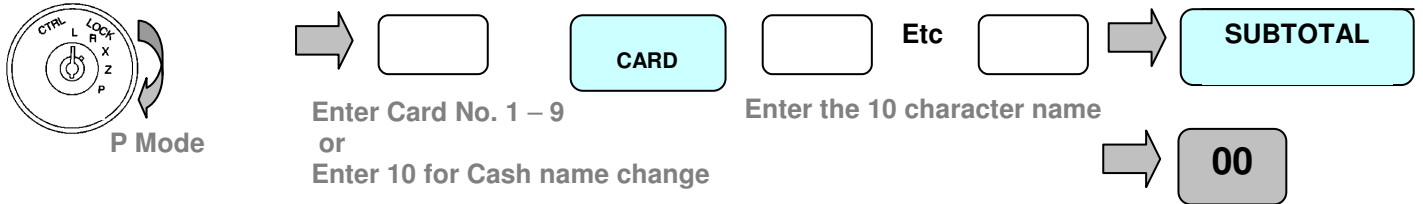

Programming VAT Rates

VAT Rates

The system can have either tax addition or extraction programmed, as default the cash register is set for tax addition. This can be changed in the system flags as required. It is possible to program 5 tax rates identified by a number 1 – 5, this number is then set to the department key. You must ensure any goods sold thru or linked to that department should be sold at the rate specified. This will provide a vat break down on both the receipt and financial report if required

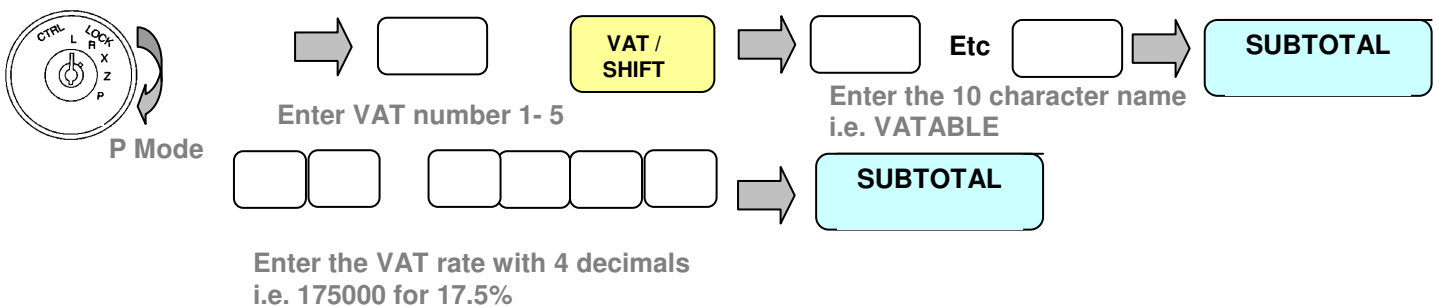

Program Settings

Programming Function keys

Copy Receipt

This function can be used to disallow the printing of copy receipts, also to disallow the printing of the past three receipts.

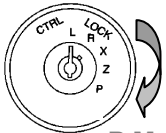

P Mode

COPY
RECPT

A

B

C

SUBTOTAL

Enter all the answers from the table below

Feature option	Choice	Answer
Allow the recalling of the three oldest copy receipts for re-printing	Yes = 0 No = 1	<input type="text" value="A"/>
Allow unlimited numbers of copy receipts to be printed	0 = No Limit 1 = 1 only	<input type="text" value="B"/>
Allow copy receipt issuance when the receipt is turned off	Yes = 0 No = 1	<input type="text" value="C"/>

#/No Sale

This is a dual function key, which allows the opening of the cash drawer without making a sale. Alternatively, the key can be used to enter a 10-digit numeric reference number at any time during a transaction. This number will be printed on the paper roll.

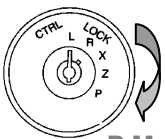

P Mode

/ NO
SALE

A

B

C

SUBTOTAL

Enter all the answers from the table below

Feature option	Choice	Answer
Compulsory reference number entry	No = 0 Yes = 1	<input type="text" value="A"/>
Enabled no sale and open drawer function	No = 1 Yes = 0	<input type="text" value="B"/>
Enabled reference no inputting	No = 1 Yes = 0	<input type="text" value="C"/>

Program Settings

Programming Currency Exchange

Euro / Currency

There are two function keys available for currency conversion. These keys are used for converting the home currency value to Euro currency allowing the operator to accept payments in Euros and one other foreign currency. The rate for home currency to Euros must always be programmed to rate 1. The second currency key should then be programmed with the currency rate from Euros to the other chosen currency.

For Example

£1 = ? Euros must be programmed to Currency 1.
 E.g. £1 = 1.58 Euros then the rate is $1 / 1.58 = 0.632511$

If CURR#2 is dollars the rate for 1\$ = ? Euros must be programmed to Currency 2
 E.g. 1\$ = 1.26 Euros then the rate is $1 / 1.26 = 0.791234$

The cash register can then work through the Euro conversion as shown

Sell £1.00 and press the CURR#1 key this will show E1.58 which is $1.00 / 0.632511$
 Press the CURR#2 key this will show \$1.26 which is $£1.00 / 0.632511 = 1.58 \text{ Euros} \times 0.791234 = \1.26
£ to Euro Rate \$ to Euro Rate

If your home currency is Euros, this option can be reversed by using the General Setting system flag. "Euro currency is home currency".

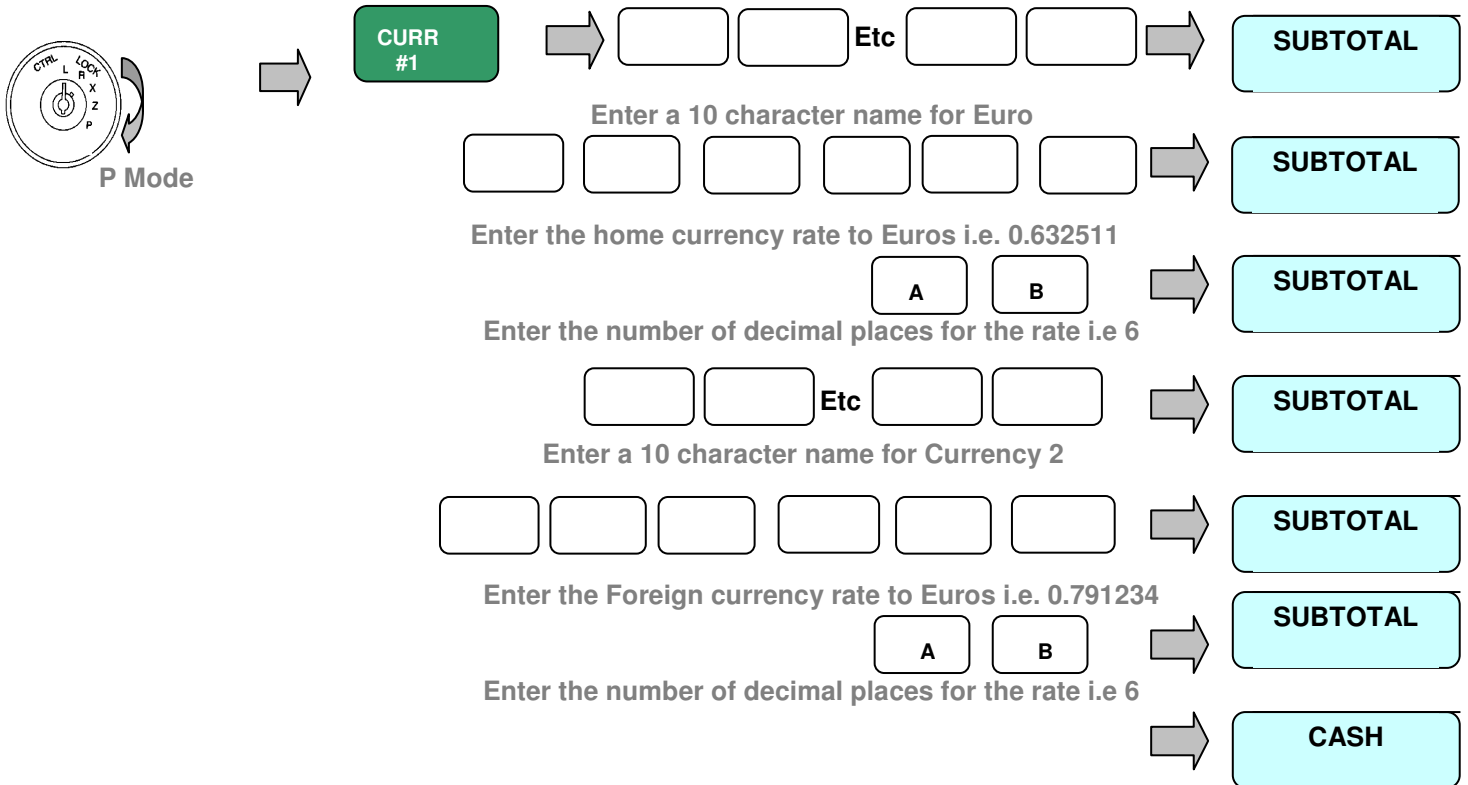

Feature option	Choice	Answer
If the machine is required to operate with Euros as the home currency then set this flag to yes and refer to the system option 8	No = 0 Yes = 1	<input type="button" value="A"/>
The number of decimal places are required for this exchange rate, (this is usually 6 in the UK)	0 - 6	<input type="button" value="B"/>

Program Settings

System Features

The register can be enhanced to better suit your needs by using the following system flags

Decimal Places / Date format and Vat add or extract

This determines basic features such as the format of the date printing. You must carry out the "Reset All Totals" procedure mentioned earlier before you are allowed to carry out the following procedure.

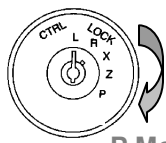

P Mode

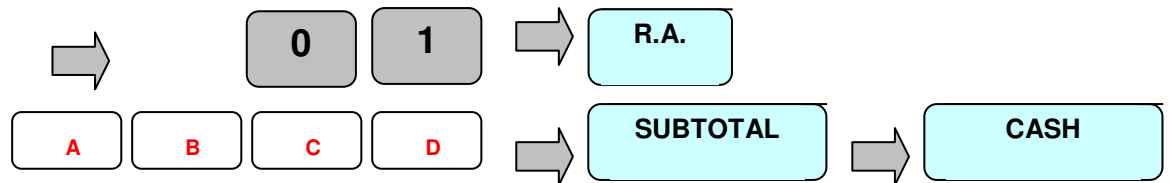

Enter all the answers from the table below

Feature option	Choice	Answer
VAT TAX and Add-on Tax Before calculations can be changed all sales totals should be reset	VAT =0 Add-on=1	<input type="text" value="A"/>
Date format	0=MM-DD-YYYY 1=DD-MM-YYYY 2=YYYY-MM-DD	<input type="text" value="B"/>
Currency Symbol	0=£ 1=\$ 2=€ 3=No symbol	<input type="text" value="C"/>
Number of decimal places used.	0 = 0 1 = 0.0 2 = 0.00 3 = 0.000	<input type="text" value="D"/>

Machine number

It is possible to program a number to identify the machine, which is printed on every receipt

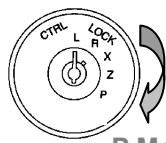

P Mode

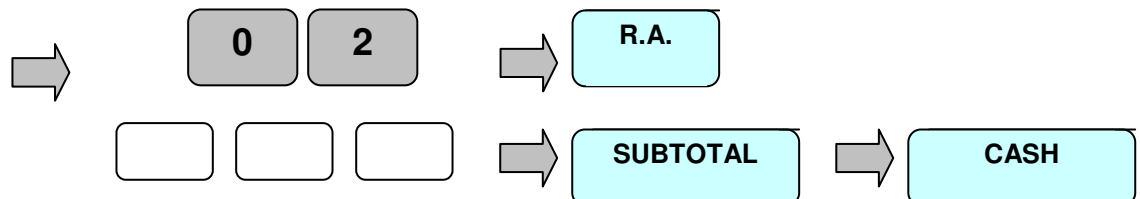

Enter the 3 digit machine identifier

Program Settings

System Features

The register can be enhanced to better suit your needs by using the following system flags

Receipt number

As each receipt is issued a consecutive number is calculated and printed, this can be reset or changed to a new starting number if required.

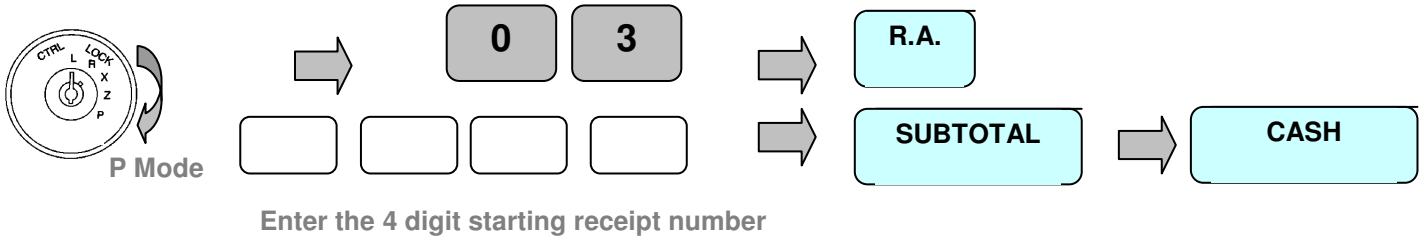

Receipt Print Formatting

This controls what information is printed on the reports.

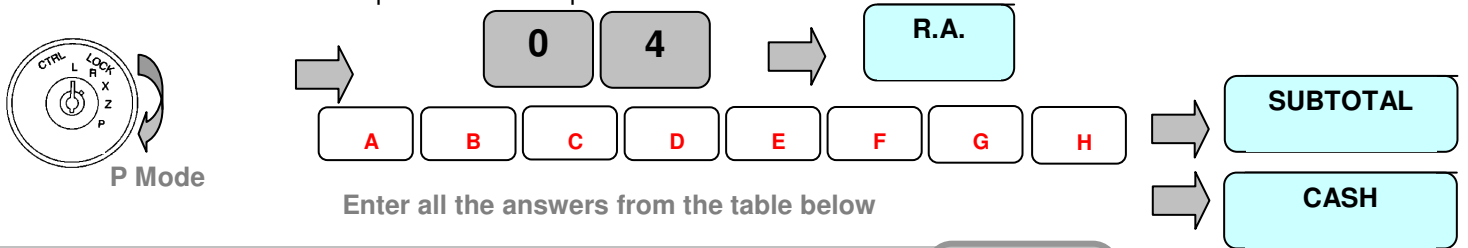

Feature option	Choice	Answer
Print the PLU Number and Department Code on the receipt.	0 = No 1 = Yes	<input type="text" value="A"/>
Stop the Paper End Sensor from operating	0 = No 1 = Yes	<input type="text" value="B"/>
Print the receipt consecutive number	0 = Yes 1 = No	<input type="text" value="C"/>
Print the total number of items sold on each receipt	0 = Yes 1 = No	<input type="text" value="D"/>
Print the Date on the receipt	0 = Yes 1 = No	<input type="text" value="E"/>
Print the time on the receipt	0 = Yes 1 = No	<input type="text" value="F"/>
Print the receipt trailer message	0 = Yes 1 = No	<input type="text" value="G"/>
Print the receipt header message	0 = Yes 1 = No	<input type="text" value="H"/>

Program Settings

Report Formatting

This controls what information is printed on the reports.

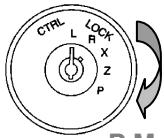

P Mode



0

6



R/A

A

B

C

D

E

F

G

H



SUBTOTAL



CASH

Enter all the answers from the table below

Feature option	Choice	Answer
Print monies Declared report on Full report	0 = No 1 = Yes	<input type="text" value="A"/>
Print Group report on Full report	0 = Yes 1 = No	<input type="text" value="B"/>
Print zero totals on financial report	0 = No 1 = Yes	<input type="text" value="C"/>
Reset daily/periodic grand total when report printed in z-mode	0 = No 1 = Yes	<input type="text" value="D"/>
Print the Clerk report with the Full report	0 = Yes 1 = No	<input type="text" value="E"/>
Print the Department report with the Full report	0 = Yes 1 = No	<input type="text" value="F"/>
Print the Periodic Grand Total on periodic reports	0 = Yes 1 = No	<input type="text" value="G"/>
Print the Daily Grand Total on financial and Full reports	0 = Yes 1 = No	<input type="text" value="H"/>

Electronic Journal / Report Options

This controls how the electronic journal will operate, and the report printing options.

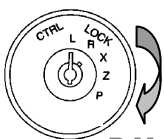

P Mode



0

7



RA

A

B

C

D

E

F



SUBTOTAL



CASH

Enter all the answers from the table below

Feature option	Choice	Answer
Force the operator to enter the value of cash in the drawer before being able to take a report.	0 = No 1 = Yes	<input type="text" value="A"/>
Print the receipt number report number on the report	0 = Yes 1 = No	<input type="text" value="B"/>
Allow the display of total cash in drawer by pressing Subtotal in X.	0 = Yes 1 = No	<input type="text" value="C"/>
Allow the electronic journal to be reset in program mode without printing	0 = Yes 1 = No	<input type="text" value="D"/>
Warn that the electronic journal is full and start a new when full	0 = Yes 1 = No	<input type="text" value="E"/>
Enable the storage of sales to the electronic journal. This Feature is turned off as standard	0 = Yes 1 = Yes	<input type="text" value="F"/>

Program Settings

General Settings

This controls the general register operation

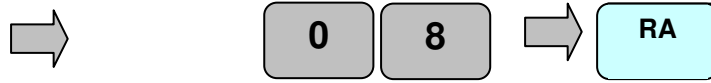
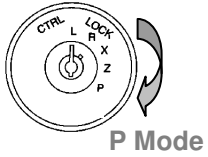

Enter all the answers from the table below

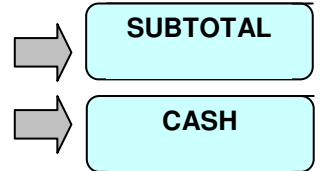

Feature option	Choice	Answer
Sound drawer alarm if open more than 5 seconds & stop operation. No drawer alarm	0=Yes 2=No 1=Normal	<input type="text" value="A"/>
Sound drawer alarm if open more than 5 seconds & allow operation	0 = No 1 = Yes	<input type="text" value="B"/>
Disable the Cancel key function	0 = No 1 = Yes	<input type="text" value="C"/>
Disable the Refund key function	0 = No 1 = Yes	<input type="text" value="D"/>
Euro is the home currency allowing conversion without using triangulation through euro in order to convert.	0 = Yes 1 = No	<input type="text" value="E"/>
Print Euro sales values as well as home currency. This will print the sales totals in Euros even if no conversion is taking place.	0 = No 1 = Yes	<input type="text" value="F"/>
Force a clerk to sign on by secret code for every sale. This requires flag G to also be set as yes	0 = No 1 = Yes	<input type="text" value="G"/>
Sign on by clerk secret code is allowed	0 = No 1 = Yes	<input type="text" value="G"/>

Self Test/Printer Feed Lines

This controls how the electronic journal and hardware test will operate

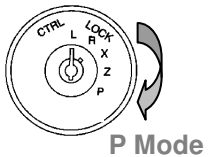

Enter the number of lines of paper to feed after a receipt

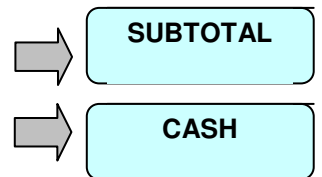

Feature options	Choice	Answer
If self test	0=No 1=Yes	<input type="text" value="A"/>
Paper Feed Lines Number (0-9)	0 – 9 default 7	<input type="text" value="B"/>

Program Settings

Exchange rate

It is possible to determine if the foreign currency exchange rate is printed.

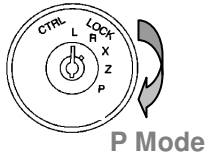

0

9



RA

A

0



SUBTOTAL



CASH

Enter all the answers from the table below

Feature option	Choice	Answer
Print the Exchange rate when doing foreign currency sale	0 = Yes 1 = No	A

Cash in Drawer Limit

If this limit is reached, then monies must be paid out from the register or a financial reset report taken. This is designed to ensure the operator knows when the maximum value of monies to be held in the drawer is reached.

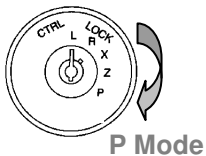

1

0



R.A.

Enter the monetary cash limit



SUBTOTAL



CASH

Printing Program Data

Program Reads

It is possible to print all pre-programmed data, using the following sequence. if you wish to stop a report during printing press CLEAR

Printing All Pre-Programmed PLU Data

This will print all pre-programmed Price Look Up codes

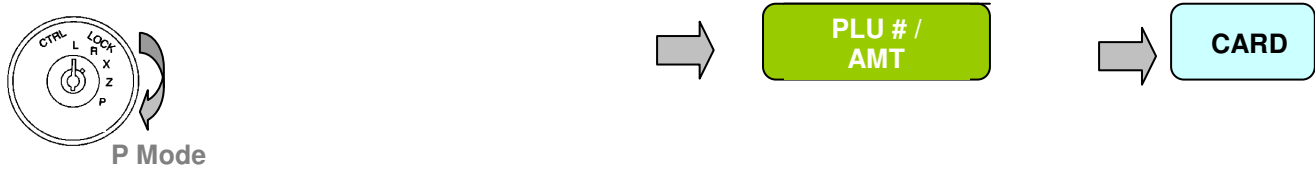

Printing a Range of Pre-Programmed PLU Data

This will print a range pre-programmed Price Look Up codes

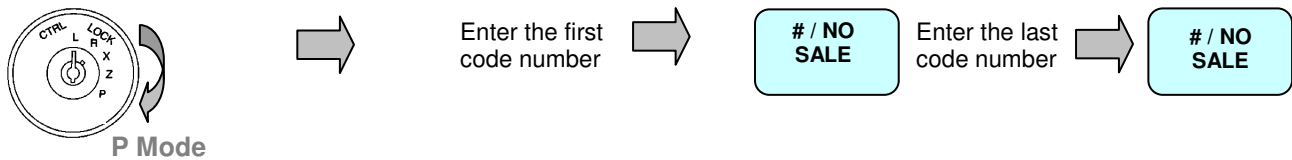

Printing all Pre-Programmed Clerk Data

This will print all pre-programmed Clerk Data

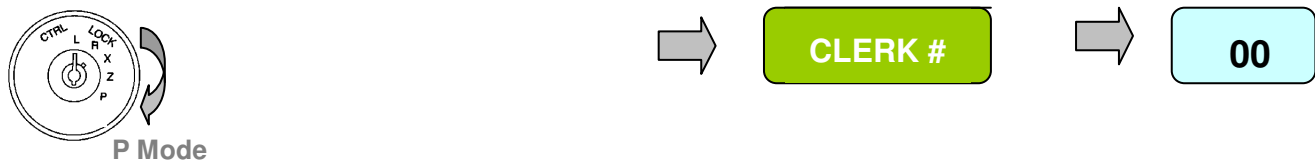

Printing Program Data

Printing all Pre-Programmed Department Data

This will print all pre-programmed Department flag data

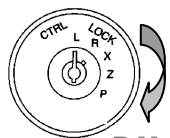

P Mode

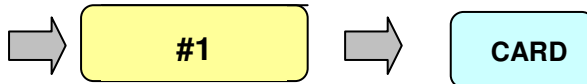

Printing all Pre-Programmed System Flag Data

This will print all pre-programmed system flag data

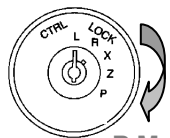

P Mode



Printing all Pre-Programmed Group Data

This will print all pre-programmed group names

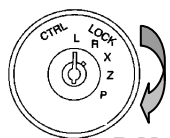

P Mode

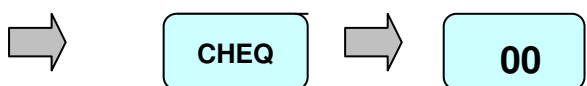

Printing all Pre-Programmed Foreign Currency Rates

This will print all pre-programmed foreign currency names

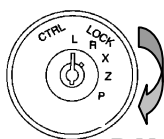

P Mode

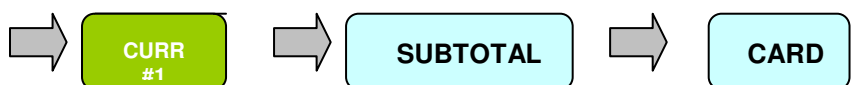

Printing Program Data

Printing all Pre-Programmed Tax Rates

This will print all pre-programmed tax names and rates

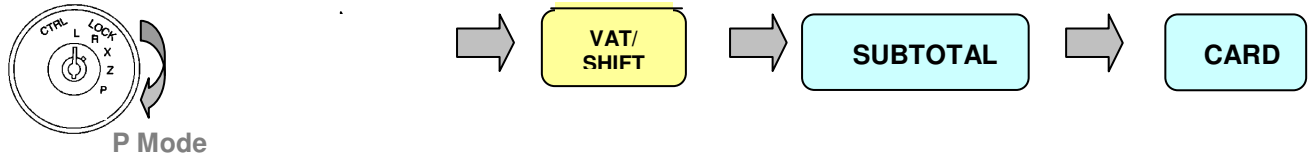

Printing all Pre-Programmed Logo Names

This will print all pre-programmed foreign currency names



Operation



Chapter 5

Sale Operation

Basic Operations

Receipt Example

Example printout

***** * YOUR RECEIPT * * THANK YOU * *****	Programmable Company header message
11/05/03 14-10 000	Date and time and register number
2X @1.00 DEPT01 T1 2.00 SUBTOT 2.35	Quantity of 2 at 1.00 value Programmable Department name, tax indicator and price Value of the sale including the Add on Tax
----- SUB-T 2.00 TAX1 17.5% 0.35 VAT TOTAL 0.35 -----	Value of the sale excluding the Add on Tax Programmable tax rate, name and the value of Tax Total of all Tax payable by all rates within this sale
TOTAL 2.35	Total amount due by the customer
----- CASH 5.00 CHANGE -2.65 -----	Total value of monies paid by the customer Value of change due to the customer
#ITEMS 2 CLERK 1 0000 THANK YOU PLEASE CALL AGAIN	Number of items purchased within this sale Programmable Company footer message

The information printed on the receipt is programmable and is decided by using the system flags. The example above shows a full detailed receipt with optional tax add on.

Displaying the time

The current time can be displayed. This will prevent the cash register from operating and can be removed by pressing the clear key

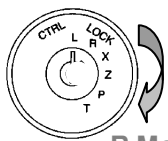

R Mode

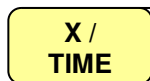

Clerk Sign On

It is possible to program a clerk with a secret number and force them to enter a secret code before a sale can be made. This provides added security and ensures that an accurate value of cash taken per clerk is calculated for the reports.

Example	1234 PASSWORD £10.00	PLU 1 Department 1 sold incorrect for the value of £2.00
----------------	-------------------------	---

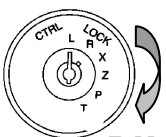

R Mode



Continue and make the sale as normal

Basic Operations

Department Sales

The Departments are used for making sales using different categories i.e. one department for Food and Non Food. This will provide analysis of the business. The reports will produce a total sales quantity and value for each department. The report will then provide a detailed analysis of the business.

Open Priced Sale

A price can be entered onto a department

<i>Example</i>	£1.23 Sale	Department 2
	£1.23 Paid	Cash

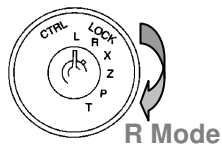

1 2 3 #2 CASH

Preset Priced Sale

It is possible to program a department with a preset price so that when the department key is pressed the price is registered automatically

<i>Example</i>	£10.50 Sale	Department 1 which is preset priced
	£10.50 Paid	Cheque

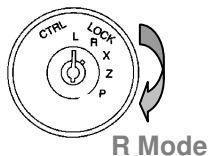

#1 CHEQ

Several Department Sales

<i>Example</i>	£ 1.23 Sale	Department 2
	£10.50 Sale	Department 1 which is preset priced
	£11.73 Paid	Cash

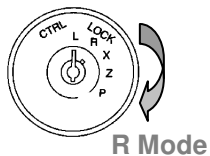

1 2 3 #2 #1 SUBTOTAL CASH

Basic Operations

The Departments are used for making sales and providing analysis of the business. The reports will produce a total sales quantity and value for each department. .

Repeating the Same Department

Pressing the department key again will result in registering another sale at the same value.

<i>Example</i>	£1.23 Sale	Department 2
	£1.23 Sale	Department 2
	£3.00 Paid	Cash

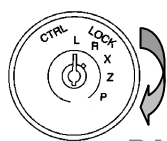

R Mode

1 2 3 #2

#2

SUBTOTAL

3 0 0 CASH

Selling Multiples of the same item using X/Time

<i>Example</i>	£ 2.46 Sale	Department 2 with a Quantity of 2 @ 1.23
	£15.00 Sale	Department 1 with a Quantity of 1.5 @ 10.00
	£20.00 Paid	Cash

The X/Time key can be used for the multiplication of items using whole or decimal quantities.

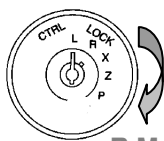

R Mode

2 X / TIME

1 2 3 #2

1 . 5 X / TIME

#1

SUBTOTAL

2 0 0 0 CASH

Basic Operations

The Departments are used for making sales and providing analysis of the business. The reports will produce a total sales quantity and value for each department.

Negative Departments

The department functions can be programmed as negative, the value can either be preset or manually entered.

<i>Example</i>	£ - 1.23 Sale	Department 3 with a negative status
	£10.50 Sale	Department 1 which is preset priced
	£ 9.27 Paid	Cash

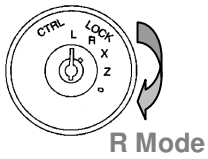

1 2 3 #3

#1

SUBTOTAL

CASH

Single Item Sale Departments

The department functions can be programmed so that they accept a price, or sell as preset then automatically cash off the sale

<i>Example</i>	£ - 1.23 Sale	Department 3 with a Single item sale status
----------------	---------------	---

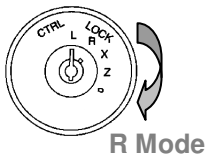

1 2 3 #3

Basic Operations

PLU (price look up) number Sales

The register allows for 1200 Price Look Up codes to be programmed to the system as preset or open priced codes. The report provides sales value and quantities for each product sold.

Open Priced Sale

A price can be entered onto a PLU code providing the status has been changed to allow manual price entry.

<i>Example</i>	£ 1.23 Sale	PLU 1
	£ 2.00 Paid	Cash

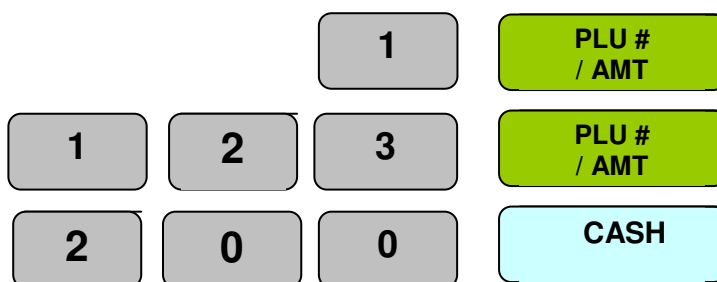
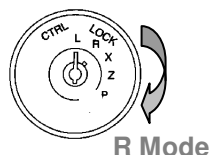

Preset Priced Sale

It is possible to program a PLU with a preset price so that when the PLU key is pressed the price is registered automatically

<i>Example</i>	£ 10.20 Sale	PLU 2 preset priced
	£ 10.20 Paid	Cheque

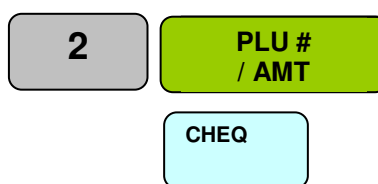
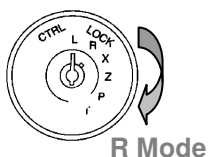

Several PLUs

<i>Example</i>	£ 1.23 Sale	PLU 1 preset priced
	£ 10.20 Sale	PLU 2 preset priced
	£ 11.43 Paid	Cash

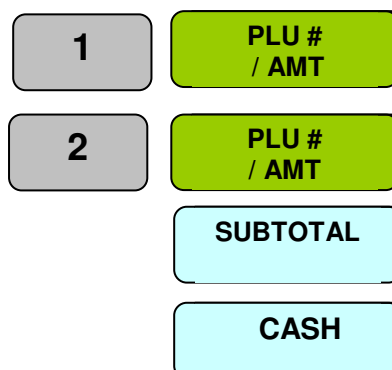
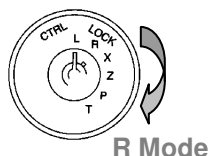

Basic Operations

Repeating the same PLU

Pressing the PLU key again will register another sale of the previous value.

<i>Example</i>	£ 1.23 Sale	Preset priced
	£ 3.00 Paid	Cash

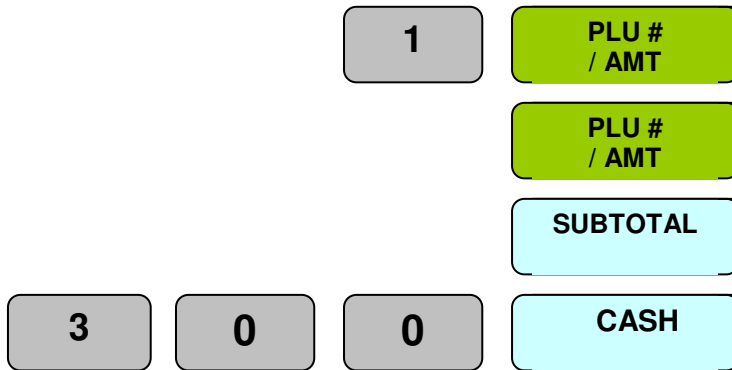
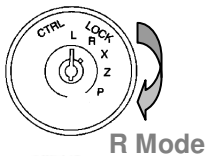

Selling Multiples of the same item using X/Time

<i>Example</i>	£ 2.46 Sale	PLU 1 with a quantity of 2 @ 1.23
	£ 15.00 Sale	PLU 2 preset priced with a quantity of 1.5 @ 10.00
	£ 20.00 Paid	Cash

The X/Time key can be used for the multiplication of PLUs using whole or decimal quantities.

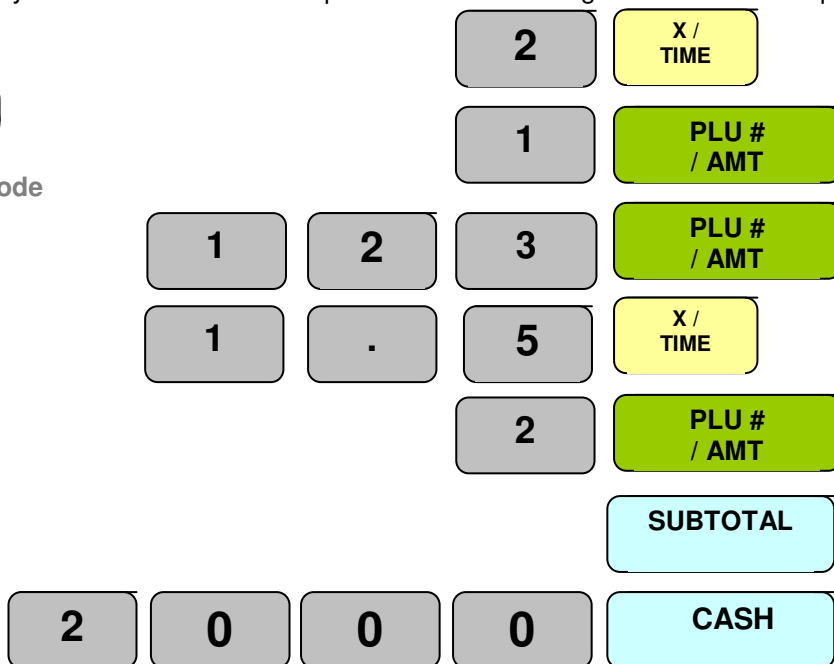
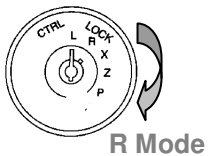

Basic Operations

Negative PLUs

The PLU functions can be programmed with negative values. The value either preset or manually entered is registered as a negative

<i>Example</i>	£ - 1.23	Preset or manually entered PLU1
----------------	----------	---------------------------------

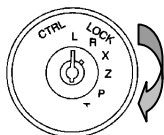

R Mode

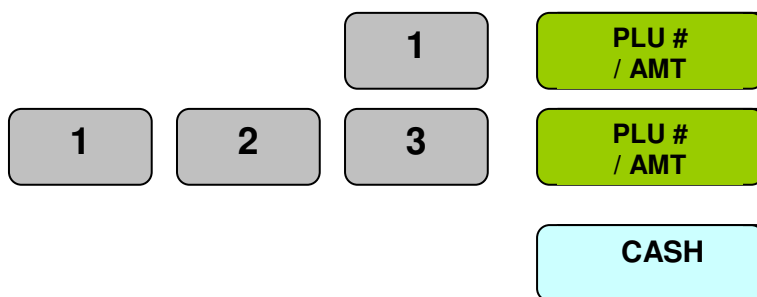

Single Item Sale PLU's

The PLU functions can be programmed with a single item sale, which allows the product to accept a price or sell as preset then automatically cash off the sale

<i>Example</i>	£ - 1.23	PLU programmed as open single item sale
----------------	----------	---

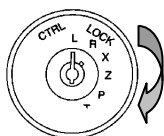

R Mode

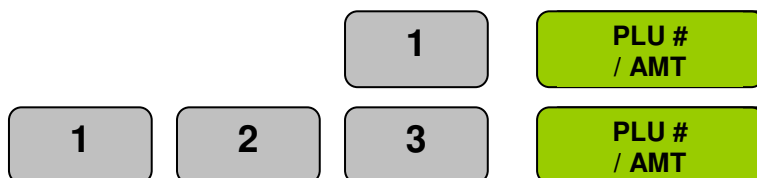

Basic Operations

Payment Operation

The register will accept four types of payment media, cash, misc tend, cheque and credit cards. It is possible to accept payment by any combination of these medias.

Card Payment

<i>Example</i>	£ 9.99 Sale	Department 3
	£ 9.99 Paid	Card type 9 (there are 9 available)

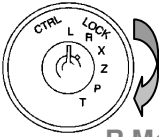

R Mode

9

9

9

#3

9

CARD

CARD

Cheque Payment

<i>Example</i>	£ 9.99 Sale	Department 3
	£ 9.99 Paid	Cheque



R Mode

9

9

9

#3

CHEQ

Mixed Payment Media

<i>Example</i>	£ 9.99 Sale	Department 3
	£ 9.00 Paid	Cheque
	£ 0.09 Paid	Misc Tend
	£ 1.00 Paid	Cash

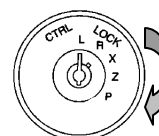

R Mode

9

9

9

#3

9

0

0

CHEQ

9

MISC TEND

1

0

0

CASH

Basic Operations

Drawer total management

It is possible to pay money into and from the cash register and have this money movement recorded on the reports

Pay In monies to the cash drawer

The value of money paid in should be entered. This is recorded on the reports as cash added to the drawer

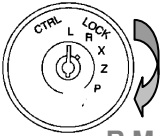
Example	5.00	Paid In
 R Mode	<input type="text" value="5"/> <input type="text" value="0"/> <input type="text" value="0"/>	<input type="button" value="R.A"/> <input type="button" value="CASH"/>

Pay Out Monies from the cash drawer

The value of money paid out should be entered. This is recorded on the reports as cash removed from the drawer.

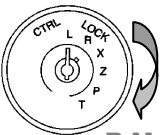
Example	1.00	Paid out
 R Mode	<input type="text" value="1"/> <input type="text" value="0"/> <input type="text" value="0"/>	<input type="button" value="P.O"/> <input type="button" value="CASH"/>

Opening the cash drawer

The # / No Sale key opens the cash drawer

 R Mode	<input type="button" value="# / NO SALE"/>
--	--

Issue a copy receipt

A copy receipt can be issued by pressing the function. Multiple copies can be issues if allowed in the system options

 R Mode	<input type="button" value="COPY RECPT"/>
--	---

Backtrack copy Receipt

It is possible to back track and print up to three previous receipts, by entering the number and pressing copy receipt

 R Mode	<input type="text" value="3"/>	<input type="button" value="COPY RECPT"/>
--	--------------------------------	---

Basic Operations

Currency Payment

This function allows payment of two foreign currencies; the Euro currency is the first rate of exchange. The system can accept partial payment of foreign and home currencies with the ability to select receipt print formats for the totals printing in both Euro and foreign currency amounts.

To make a sale in Euros the Curr1 key should be pressed immediately after the subtotal key followed by the payment function. If a sale is to be made in another currency the subtotal key should be pressed followed by the Curr2 key.

Payment in Euros

The Euro function is always assumed currency 1 and in this example, the Euro rate is 0.791234, which has been pre-programmed to the currency key.

Example	£1.00 2.00 EUROS	Department 1 £1.00 / 0.791234 = 1.26 Euros Cash 2.00 Euros x 0.791234 = £2.52
----------------	---------------------	--

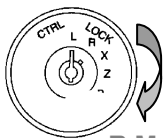

R Mode

1 0 0 #1

SUBTOTAL

CURR #1

2 0 0 CASH

Payment in Foreign Currency

The Euro function is always assumed to be currency 1 and in this example the Euros rate is 0.791234 which has been pre-programmed to the Curr1 key. If another currency is to be used this should be programmed to Curr2 key. In this example Dollars to Euros is assumed to be 0.632511 programmed to Curr2.

Example	£1.00 SALE	Department 1 £1.00 / 0.632511 Euro Rate = 1.58 Euros x 0.791234 \$ to Euro Rate = 1.26\$
	\$ 5.00 PAID	Cash \$5.00 / 0.632511 = 7.90 Euros x 0.791234 = £ 6.25

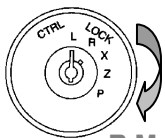

R Mode

1 0 0 #1

SUBTOTAL

CURR #2

5 0 0 CASH

Basic Operations

Monetary Discounts

The system allows two function keys to be programmed as discount or premium either as a monetary or a percentage value. The function reports to totals on the financial report recording the value of discounts or premiums given. If the % key is pressed immediately after the department or PLU, the sales value is reported net to the financial report of the % value. Alternatively, if the % key is pressed after the subtotal key only the sales total is reported as a net value and the departments and PLUs are reported gross..

Item Monetary Discount

The discount is entered immediately after the item, ensuring the values are reported net of discount to the department and PLU report. This operation is available as standard

Example £10.00 – £1.50 discount Department 1 to report £8.50p and £1.50p discount

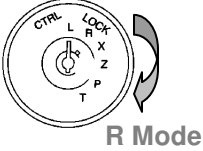

R Mode

1	0	0	0	#1
	1	5	0	% 1 (-)
				SUBTOTAL
2	0	0	0	CASH

Sale Monetary Discount

The discount is entered immediately after the subtotal key. The values are reported gross to the department and PLU Report. This operation is available using the programming of the %1 and %2 keys

Example £1.00 Department 1 to report £1.00
 £10.00 Department 1 to report £10.00
 £1.60 discount

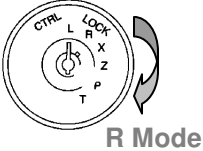

R Mode

	1	0	0	#1
1	1	0	0	#1
				SUBTOTAL
	1	6	0	% 1 (-)
				SUBTOTAL
2	0	0	0	CASH

Basic Operations

Percentage Discounts

The system allows two function keys to be programmed as discount or premium operation keys either as a monetary or a percentage value. The function reports to the financial report recording the value of discounts or premiums given. If the % key is pressed immediately after the item, the sales value is reported net of the value. Alternatively, if the key is pressed after the subtotal key only the sales total is reported as a net value and the items are reported gross. It is possible to preset the value of the % keys so that when the key is pressed the discount or surcharge is applied automatically.

Item % Discount

The discount is entered immediately after the item ensuring the values are reported net of discount to the department and PLU report. This operation is available as standard and will operate discounts up to two decimal places.

Example	£10.00 – 20.5%	Department 1 to report 7.95 and £2.05 discount
----------------	----------------	--

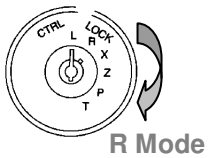

1	0	0	0	#1
2	0	.	5	% 2 (%-)
				SUBTOTAL
2	0	0	0	CASH

Sale % Discount

The discount is entered immediately after the subtotal key. The values are reported gross to the department and PLU Report. This operation is available using the programming of the %1 and %2 keys

Example	£1.00 £10.00	Department 2 to report £1.00 Department 1 to report £10.00 Discount to report -10% £1.10 %2 discount
----------------	-----------------	--

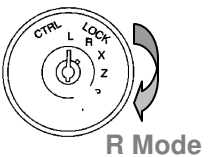

	1	0	0	#2
1	0	0	0	#1
				SUBTOTAL
1	0	0	0	% 2 (%-)
				SUBTOTAL
2	0	0	0	CASH

Basic Operations

Monetary Surcharges

The system allows two function keys to be programmed as discount or premium operation keys either as a monetary or a percentage value. The function reports to totals on the financial report recording the value of discounts or premiums given. If the % key is pressed immediately after the item, the sales value is reported net of the value. Alternatively, if the key is pressed after the subtotal key only the sales total is reported as a net value and the items are reported gross. It is possible to preset the value of the % keys so that when the key is pressed the discount or surcharge is applied automatically.

Item Monetary Surcharge

The surcharge is entered immediately after the item, ensuring the values are reported net of discount to the department and PLU report. This operation is available using the programming of the %1 and %2 keys

<i>Example</i>	£10.00 + 150P	Department 1 to report £11.50p and 1.50p %1 Surcharge
----------------	---------------	---

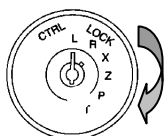

R Mode

1	0	0	0	#1
	1	5	0	% 1 (-)
				SUBTOTAL
2	0	0	0	CASH

Sale Monetary Surcharge

The surcharge is entered immediately after the subtotal key. The values are reported gross to the department and PLU Report. This operation is available using the programming of the %1 and %2 keys

<i>Example</i>	£1.00	Department 2 to report £1.00
	£10.00	Department 1 to report £10.00
	£1.60 Surcharge	Surcharge to report £1.60 %2 Surcharge

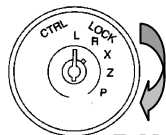

R Mode

	1	0	0	#2
1	0	0	0	#1
				SUBTOTAL
	1	6	0	% 1 (-)
				SUBTOTAL
2	0	0	0	CASH

Basic Operations

Percentage Surcharges

The system allows two function keys to be programmed as discount or premium operation keys either as a monetary or a percentage value. The function reports to totals on the financial report recording the value of discounts or premiums given. If the % key is pressed immediately after the item, the sales value is reported net of the value. Alternatively, if the key is pressed after the subtotal key only the sales total is reported as a net value and the items are reported gross. It is possible to preset the value of the % keys so that when the key is pressed the discount or surcharge is applied automatically.

Item % Surcharge

The discount is entered immediately after the item, ensuring the values are reported net of discount to the department and PLU report. This operation is available using the programming of the %1 and %2 keys

Example	£10.00 + 20.5%	Department 1 to report £12.05 and £2.05 %2 Surcharge
----------------	----------------	--

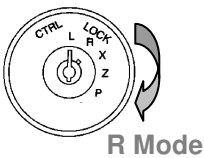

1	0	0	0	#1
2	0	.	5	% 2 (%-)
				SUBTOTAL
2	0	0	0	CASH

Sale % Surcharge

The discount is entered immediately after the subtotal key. The values are reported gross to the department and PLU Report. This operation is available using the programming of the %1 and %2 keys

Example	£1.00	Department 2 to report £1.00
	£10.00	Department 1 to report £10.00
	50% +	Surcharge to report £5.50%2 surcharge

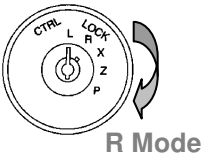

	1	0	0	#2
1	0	0	0	#2
				SUBTOTAL
		5	0	% 1 (-)
2	0	0	0	SUBTOTAL
				CASH

Basic Operations

Corrections during a sale

The system allows for varying forms of correction within a transaction, each of which are outlined below.

Void Last

This will remove the last item sold from the sale total

<i>Example</i>	£1.00	Department 2
	£10.00	Department 1 sold incorrect for the value of £2.00

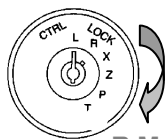

R Mode

1	0	0	#2
1	0	0	#1
VOID LAST			
SUBTOTAL			
CASH			

Refund Item – within a sale

This can be used to remove any item within the current sale by pressing the refund/cancel item key and re-entering the item

<i>Example</i>	£1.00	Department 1 sold incorrectly
	£2.00	Department 2

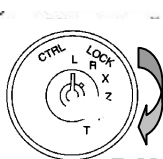

R Mode

1	0	0	#1
2	0	0	#2
REFND CANCL			
1	0	0	#1
SUBTOTAL			
CASH			

Basic Operations

Outside of Sale Corrections

The system allows for varying forms of correction within a transaction each of which are outlined below.

Refund – outside of a sale

This is used to remove an item which may has been returned for a money refund.

<i>Example</i>	£1.00	Refund Department at £1.00
	£ -1.00	Initially Paid for by Cash

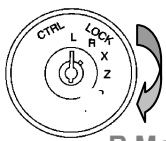

R Mode

REFND
CANCL

1 0 0 #1

CASH

Cancel Transaction

If a transaction has been entered incorrectly, the whole sale can be cancelled.

<i>Example</i>	£1.00	Department 1
	£2.00	Department 2

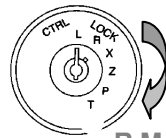

R Mode

1 0 0 #1

2 0 0 #2

SUBTOTAL

REFND
CANCL

Void a whole transaction

The void mode is a replica of register mode but all sales are subtracted rather than added to the totals

<i>Example</i>	£1.00	Refund Department at £1.00
	£ -1.00	Initially Paid for by Cash

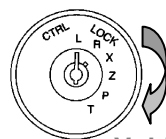

Void Mode

1 0 0 #1

CASH

Training Mode

Starting Training Mode

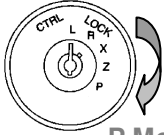

P Mode

5	5	5	SUBTOTAL
The display will show the word Password			
3	3	5	5
			CASH

Register Training Mode

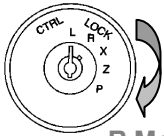

R Mode

Make sales as normal

Ending Training Mode

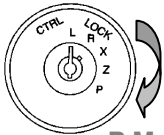

P Mode

3	3	3	SUBTOTAL
The display will show the word Password			
3	3	5	5
			CASH

Training mode financial Report

It is possible to print a financial report showing how much monies/activity has been entered during training

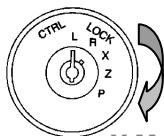

X Mode

2	2	8	CASH
---	---	---	------

Chapter 6

Reporting

Report Printing

Reporting Explained

The cash register has two reporting modes one for reading of sales data and the other for reading and resetting. The mode position access is controlled by keys with only the **OW** key accessing the reporting modes. When the key is turned to the X and Z position the total monies taken is displayed on screen.

X – Used for the printing of sales data without resetting the totals

Z - Used for the printing of sales data and resetting the values back to zero.

Over the following pages are examples of reports, which explain all totals. The reports produced for each individual register will vary depending on which functions are used i.e. if no cheque payments have been accepted then this total will not print. The report format can be customised using the system report print options.

Displaying Cash in Drawer

When the mode key is turned to X the total monies taken is displayed. Pressing this key will identify how much of that is cash. This feature is allowed or disallowed using program flags. It is also possible to press the Cash, Cheque, Card or Miscellaneous tender keys in order to display the in drawer totals, depending on the pre-programmed system flags.

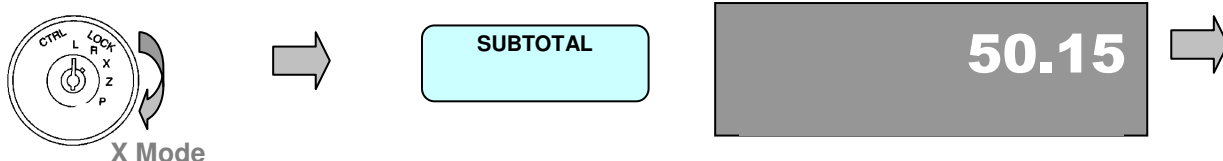

Printing a short Read of the Drawer totals

This displays the current value in drawer total

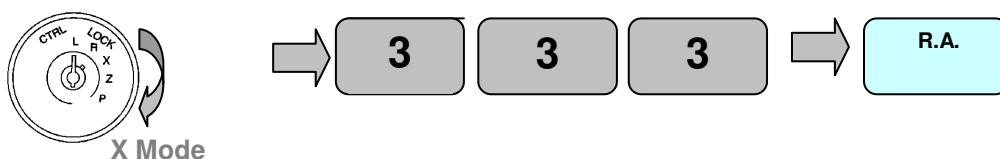

Enter Cash Declared

The cash declared can be forced before the printing of a financial report or entered optionally by pressing the CURR #1 key in Z mode. When prompted the values are entered as shown below.

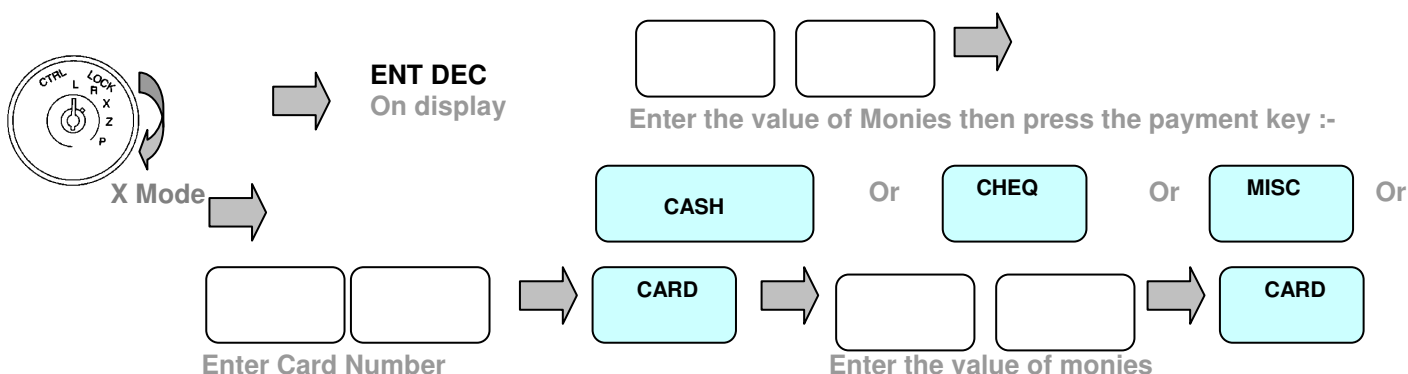

Reporting Printing



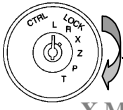



Report Procedures

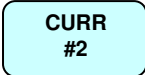
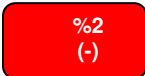
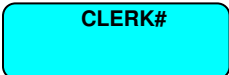
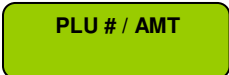
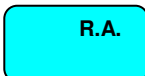

X Mode

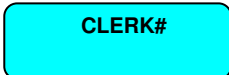
Read Reports

To print the following reports turn the mode key to the X position using the OW key and press the key shown

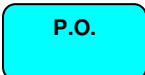
Full report			This prints all financial information. It is possible using the system flags to optionally print clerks, groups etc.
Financial			This prints all financial information.
Full Department			This prints the sales quantity and value for all the Departments sold. Also the total sales for any PLU's linked to departments for sales reporting. This report can also be optionally printed on the financial report
Full Clerk Report			This prints the total monies taken for all clerks. This report can be optionally printed on the financial report
Full PLU			This prints the sales quantity and value for all the PLU's sold
Full Hourly			This prints the total monies taken per hour
Individual Department			This prints the sales quantity and value for the selected Departments sold, including the total for any PLU's linked to departments for sales reporting
Individual Clerk	Enter the Clerk No.		This prints the total monies taken for the clerk
Individual PLU	Enter the PLU No.		This prints the sales quantity and value for the selected PLU
Range PLU	Enter the PLU No Start. Enter the PLU No. End	 	This prints the sales quantity and value for the selected PLU range
Periodic Financial			This is the period i.e. monthly / weekly copy of the financial report

Reporting Printing

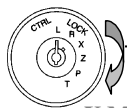

X Mode

Read Reports

To print the following reports turn the mode key to the X position using the OW key and press the key shown

Void report	<div style="display: flex; gap: 10px;"> <div style="border: 1px solid black; border-radius: 5px; padding: 5px; width: 40px; text-align: center;">7</div> <div style="border: 1px solid black; border-radius: 5px; padding: 5px; width: 40px; text-align: center;">7</div> <div style="border: 1px solid black; border-radius: 5px; padding: 5px; width: 40px; text-align: center;">7</div> <div style="background-color: cyan; border: 1px solid black; border-radius: 5px; padding: 5px; width: 40px; text-align: center;">R.A</div> </div>	This will print out all void and refunds
Short Financial	<div style="display: flex; gap: 10px;"> <div style="border: 1px solid black; border-radius: 5px; padding: 5px; width: 40px; text-align: center;">3</div> <div style="border: 1px solid black; border-radius: 5px; padding: 5px; width: 40px; text-align: center;">3</div> <div style="border: 1px solid black; border-radius: 5px; padding: 5px; width: 40px; text-align: center;">3</div> <div style="background-color: cyan; border: 1px solid black; border-radius: 5px; padding: 5px; width: 40px; text-align: center;">R.A</div> </div>	This will print the total sums of monies in drawer.
Daily sales	<div style="background-color: yellow; border: 1px solid black; border-radius: 5px; padding: 5px; width: 60px; text-align: center; margin: 0 auto;">VAT SHIFT</div>	This report shows the total value of monies per day.
Group sales	<div style="display: flex; gap: 10px;"> <div style="border: 1px solid black; border-radius: 5px; padding: 5px; width: 40px; text-align: center;">5</div> <div style="border: 1px solid black; border-radius: 5px; padding: 5px; width: 40px; text-align: center;">5</div> <div style="border: 1px solid black; border-radius: 5px; padding: 5px; width: 40px; text-align: center;">5</div> <div style="background-color: cyan; border: 1px solid black; border-radius: 5px; padding: 5px; width: 40px; text-align: center;">R/A</div> </div>	This shows the total quantity and value per group
Department Short Group	<div style="display: flex; gap: 10px;"> <div style="border: 1px solid black; border-radius: 5px; padding: 5px; width: 40px; text-align: center;">1</div> <div style="border: 1px solid black; border-radius: 5px; padding: 5px; width: 40px; text-align: center;">1</div> <div style="border: 1px solid black; border-radius: 5px; padding: 5px; width: 40px; text-align: center;">1</div> <div style="background-color: cyan; border: 1px solid black; border-radius: 5px; padding: 5px; width: 40px; text-align: center;">%2</div> </div>	This shows the total value of groups per department
Electronic Journal	<div style="background-color: red; color: white; border: 1px solid black; border-radius: 5px; padding: 5px; width: 60px; text-align: center; margin: 0 auto;">%1 (%-)</div>	This prints the full days audit roll. This feature must be enabled using the program option 7 setting.
Training full report	<div style="display: flex; gap: 10px;"> <div style="border: 1px solid black; border-radius: 5px; padding: 5px; width: 40px; text-align: center;">2</div> <div style="border: 1px solid black; border-radius: 5px; padding: 5px; width: 40px; text-align: center;">2</div> <div style="border: 1px solid black; border-radius: 5px; padding: 5px; width: 40px; text-align: center;">8</div> <div style="background-color: cyan; border: 1px solid black; border-radius: 5px; padding: 5px; width: 40px; text-align: center;">CASH-</div> </div>	This prints out the full report, include dept, group, financial and clerk report according to the fixed sequence, in TRAIN mode

Report Printing

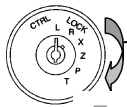

Z mode

Reset Reports

To print the following reports turn the mode key to the Z position using the OW key and press the key shown

Full report		This prints all financial information. It is possible using the system flags to optionally print clerks, groups etc.
Full Department		This prints the sales quantity and value for all the Departments sold. Also the total sales for any PLU's linked to departments for sales reporting. This report can also be optionally printed on the financial report
Full Clerk Report		This prints the total monies taken for all clerks This report can be optionally printed on the financial report
Full PLU		This prints the sales quantity and value for all the PLU's sold
Full Hourly		This prints the total monies taken per hour
Periodic Financial		This is the period i.e. monthly / weekly copy of the financial report
Electronic Journal		This prints the full days audit roll. This feature must be enabled using the program option 7 setting.
Daily sales		This report shows the total value of monies per day.
Department Short Group		This shows the total value of groups per department
Training full report		This prints out the full report, include dept, group, financial and clerk report according to the fixed sequence, in TRAIN mode
Declared Cash		This accepts the declared monies as shown previously and prints the declared report.

Report Printing

Sample Reports

Void Report

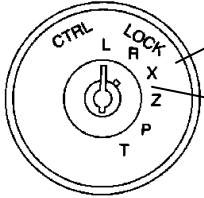

X – Prints Reports and keep totals

Z - Prints the sales totals and resets the figures for the report back to zero

7

7

7

R/A

VOID REPORT

GROSS 37.84

This is the total retail value of goods sold

NET 37.30

This is the net value of monies taken for goods sold.

REFUND

This is the total value of refunds

37.30

ERROR CORRECT 1N

This is the total value of last item voids

37.30

CANCEL

This is the total value of cancelled sales

37.30

REPORT TOTAL

This is the total value of void mode sales

37.30

Clerk Report

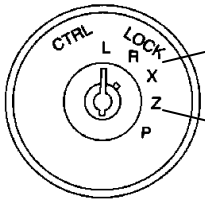

X - Prints Reports and keep totals

Z - Prints the sales totals and resets the figures for the report back to zero

CLERK #

```

*****
      CLERK REPORT
*****
CLERK 1
T.SALE          27N
                37.30
TAX              19N
                0.54
TOTAL           37.30
TAX TOTAL       0.54
*****

```

This is the total quantity and value of clerk A's sales

This is the number of tax transactions and the value of vat per rate

This is the total value of sales

This is the total value of vat for all rates

Report Printing

Full Report

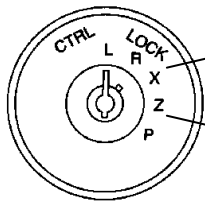

X – Prints Reports and keep totals

Z - Prints the sales totals and resets the figures for the report back to zero

CASH

```

***** Z *****
      Z-FULL REPORT
      Z0016#
*****
DEPARTMENT REPORT
*****
DEPT01      91.95%
  28.00X      34.30
DEPT02      91.95%
  2.00X       3.00
REPORT TOTAL 37.30

TAX1 17.5%   19N
              0.54
TOTAL        37.84
*****
      GROUP REPORT
*****
GROUP 1      3.00
*****
*****
      FINANCIAL REPORT
*****
GROSS        37.84
NET TOTAL
              37.84
ERROR CORRECT
              0.00
%+
              0.00
+
              0.00
%-
              0.00
-
              0.00
REFUND
              0.00
CANCEL
              0.00
DRAWER TOTAL 37.84
CASH         29N
              33.23
FCE0 1      3N
              1.74
  
```

Z indicates a reset report has been done and X read

This is the type of report that has been printed

This is the report number

This is the department name and % of total department sales

This is the quantity and value of goods sold per department

This is Value of goods prior to tax and including discounts and premiums

This is the vat name and quantity for that vat rate

This is the total value of vat

This is the total value of goods including discounts/premiums and tax

This is the total value of goods sold per group (programmable)

This is the retail value of goods sold before discounts

This is the total value of error corrections / last item voids

This is the total value of surcharge given

This is the total value of discount given

This is the total value of refunds

This is the total value of cancelled sales

This is the monetary value of goods sold

The number of cash sales and value in drawer

The number of foreign currency 1/Euro sales and value in drawer

Report Printing

Full Report Continued

CHEQUE	1N	The number of Cheque sales and the value in drawer
	1.00	
MISC	1N	The number of miscellaneous tender sales and value in drawer
	0.50	
CARD 1	1N	The number of Credit Card sales and value in drawer
	2.00	Etc for all credit card types used
CHEQ - ID	1.00	This is the total value of cheque monies in drawer
MISC - ID	0.50	This is the total value of miscellaneous monies in the drawer
CASH - ID	33.23	This is the total value of cash in the drawer
CARD - ID	2.00	This is the total value of card monies in drawer
FCE01-ID	1.74	This is the total value of foreign currency 1 monies in drawer
GRAND TOTAL	110.50	This is the running total for the machine (programmable reset)

CLERK REPORT		

CLERK 1		
T.SALE	27N	This is the total quantity and value of clerk A's sales
	37.30	
TAX	19N	This is the number of tax transactions and the value of vat per rate
	0.54	
TOTAL	37.30	This is the total value of sales
TAX TOTAL	0.54	This is the total value of vat for all rates

Declared Report

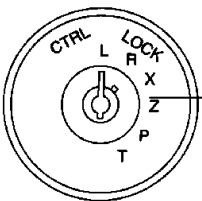

Z - Prints the sales totals and resets the figures for the report back to zero

Note :- Please refer to Enter Cash Declared page

CURR
#1

DECLARED REPORT		

CASH-ID	33.23	This is the total value of cash in drawer
CASH SHORT	33.23	This shows the over or under compared to the value declared
DEC TOTAL	33.23	This shows total value declared
DRAWER TOTAL	33.23	This is the total sum on monies in the drawer

Report Printing

Department Report

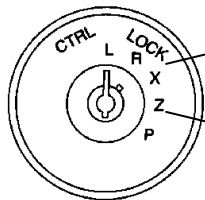

X – Prints Reports and keep totals

Z - Prints the sales totals and resets the figures for the report back to zero

%2 (-)

```
*****
DEPARTMENT REPORT
*****
DEPT01      91.95%
 28.00X      34.30
DEPT02      91.95%
  2.00X       3.00
REPORT TOTAL 37.30

TAX1 17.5%   19N
              0.54
TOTAL        37.84
```

This is the department name and % of total department sales
This is the quantity and value of goods sold per department

This is Value of goods taken from the financial

This is the vat name and quantity for that vat rate
This is the total value of vat

This is the total value of goods including discounts/premiums and tax

Group Report

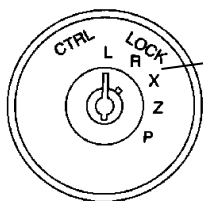

X – Prints Reports and keep totals

5

5

5

R/A

```
*****
GROUP REPORT
*****
GROUP 1      3.00
*****
```

This is the total value of goods sold per group (programmable)

Report Printing

Short Department / Group report

X - Prints Reports and keep totals

Z - Prints the sales totals and resets the figures for the report back to zero

1 1 1 %2 (-)

```

*****
DEPTREP SHORT GRP
*****
GROUP 1
DEPT02      8.04%
   2.00      3.00
TOTAL
   2.00      3.00
*****
REPORT TOTAL 37.30

```

This is the group which the departments are linked to
 This is the department description and the % of overall sales
 This is the quantity and value for this department
 This is the total quantity and value for the department report
 The quantity and value per group is shown

This is the total value of goods sold from the financial sales.

PLU Report

X - Prints Reports and keep totals

Z - Prints the sales totals and resets the figures for the report back to zero

PLU # / AMT

```

*****
PLU REPORT
*****
COUNT      TOTAL
DEPT02
0001PLU     100.00%
   1.00      1.00
TOTAL
   1.00      1.00
*****
REPORT TOTAL
   1.00      1.00

```

The department to which the PLU is linked is shown
 The PLU description and percentage of the total sales is shown
 The quantity and value per product is shown

This is the total quantity and value for all products

Report Printing

Daily Report

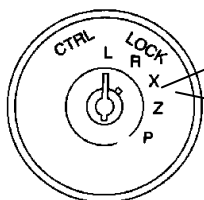

X - Prints Reports and keep totals

Z - Prints the sales totals and resets the figures for the report back to zero

VAT
SHIFT

DAILY REPORT

DAY

	COUNT	TOTAL
08		100.00%
	79	109.50

TOTAL

79	109.50
----	--------

This is the quantity and value of sales per day of the month

This is the total value of goods sold from the financial sales.

Hourly Report

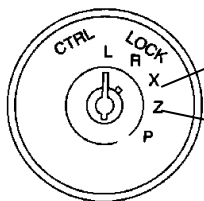

X - Prints Reports and keep totals

Z - Prints the sales totals and resets the figures for the report back to zero

R/A

HOURLY REPORT

TIME

TIME	COUNT	TOTAL
08.00		100.00%
	20	10.00

TOTAL

20	10.00
----	-------

This is the total quantity and value per time period and the % of total sales.

This is the total quantity and value for all hours

Chapter 7

Trouble Shooting

Trouble Shooting

Error Messages

The register has error numbers to identify the cause of the fault. If no error number is shown, the error is a simple mis-operation, which can be cleared by pressing clear

- EJ Z RED** The electronic journal is full and must be reset using the appropriate Z report. This warning message can be turned off if required, and the electronic journal will then automatically reset.

- E00** Operation error such as an attempt to sell a descriptive PLU without first selling a priced product
- E01** Return to the original mode position and finalise the operation
- E02** A sale cannot be finalised without entering the amount tendered, or an attempt to enter a reference number has been made and this feature is disabled.
- E03** This sequence is only allowed in Manager Mode
- E04** This operation has been disallowed
- E05** No price has been programmed to the preset only product
- E15** Not enough monies i.e. attempting to pay out more monies than is in the drawer
- E21** The cash in drawer limit has been reached either pay out monies from cash drawer or Z reset the financial totals.

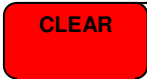
- Noise Only** This is an incorrect key sequence press  or the mode lock has been changed return to the original mode position

Problem Solving

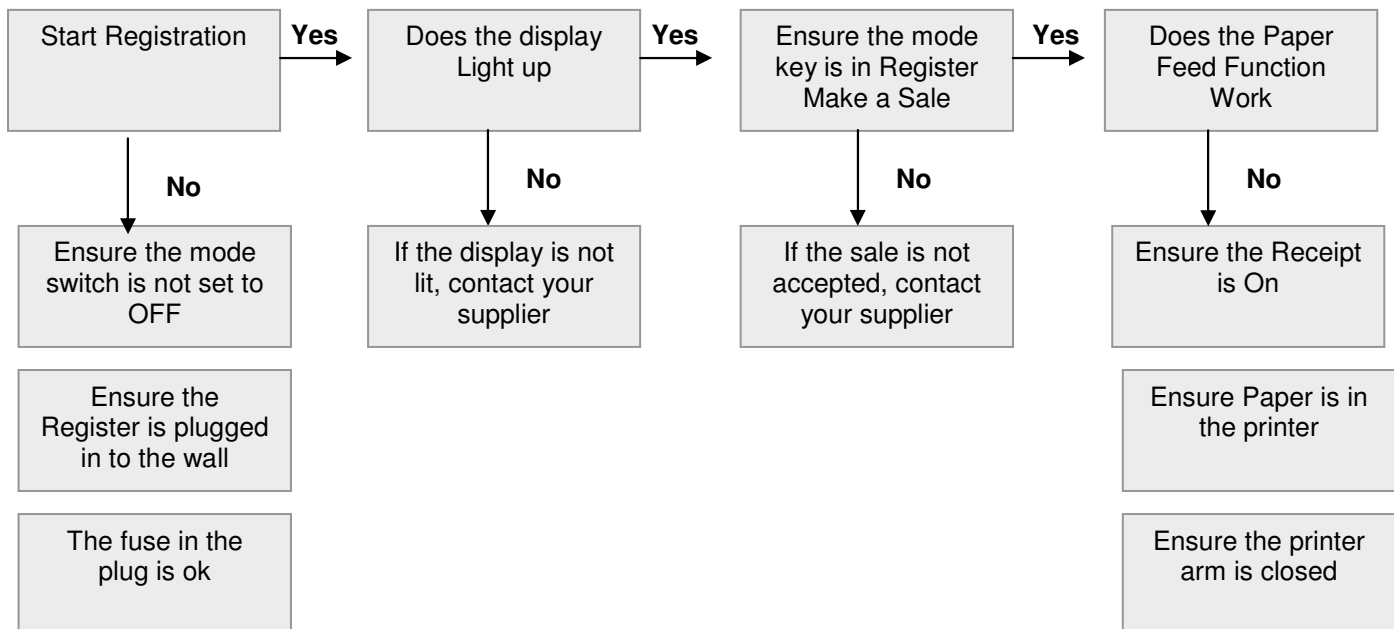

Trouble shooting

Self Tests

If there appears to be a problem with either the drawer or printer, it is possible to carry out a print test routine and a drawer test routine. It should be noted, that the drawer is lockable and should be opened for the test, there is also a manual release level on the base of the drawer in case of power failure.

Enabling/ disabling the Self Tests

The self-test must be enabled before a test can be carried out; it is also advisable to disable the option once the tests are complete.

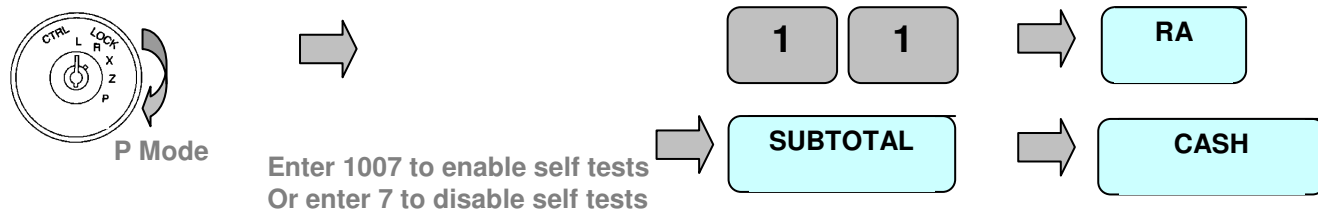

Self Test Procedure

It is possible to enforce a password entry before any programming can be started

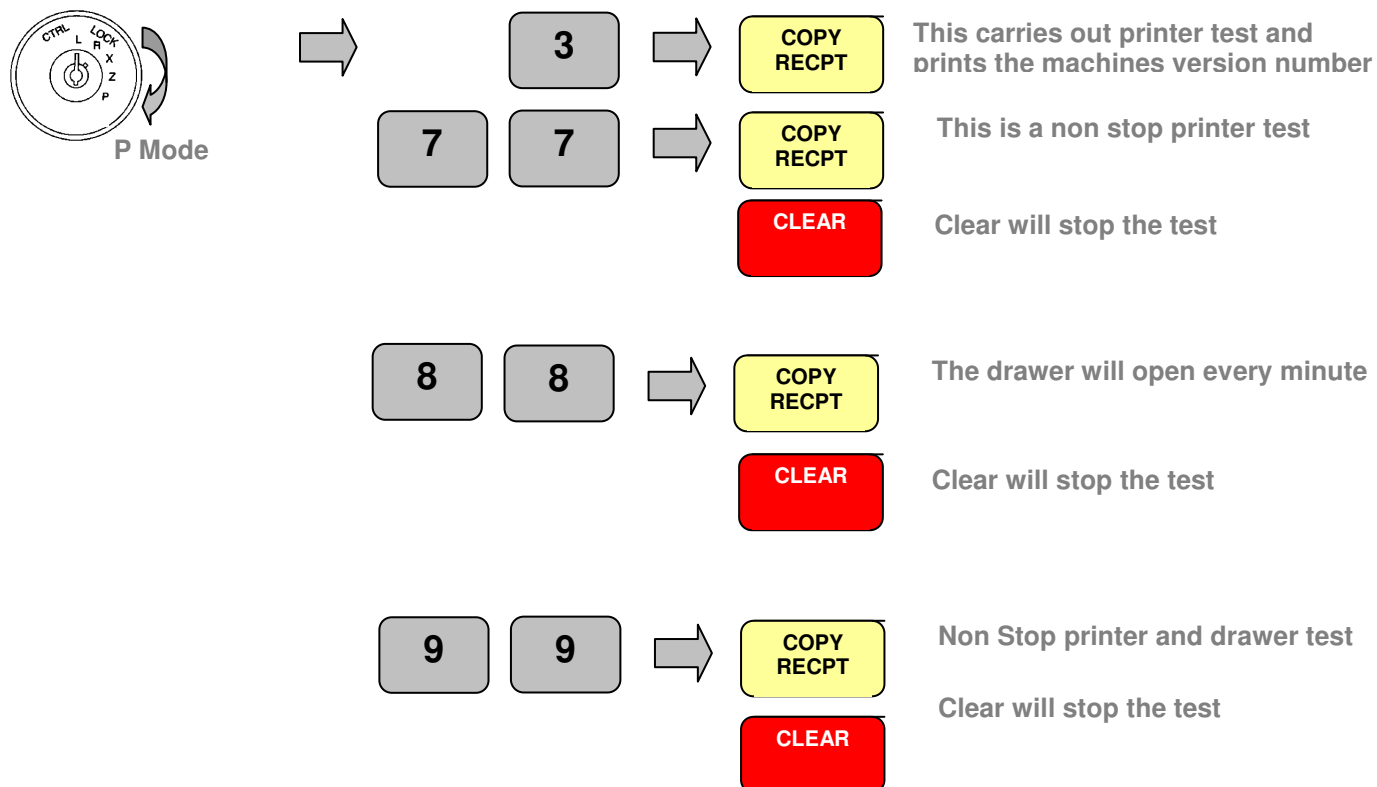

Specifications

Specifications

Keyboard

38 Functions including Numeric

Raised functions keys with 8 Departments as standard.

A Wet cover is available as a purchasable parts option

Printer

1 station thermal printer.

18 characters of print

57mm x diameter 70mm wide Paper Roll

Speed: Approx. 6 lines/sec.

Memory

1200 Product Look Ups

8 Departments – 99 in memory

15 Clerks

Size

405 (W) X 423(D) X228 (H) mm (Including Drawer)

Weight

Approx. 12Kg

Drawer

The drawer has a four note and eight coin compartments

